

T2[®] Alpha

Femur Retrograde Nailing System



T2 Alpha Femur Retrograde

The **innovation** you expect meets a **design** you've never experienced.

Redefined Nail Design

Distal locking configuration¹

- ▶ Added locking options, three planes of fixation, and the most distal screw 6mm from the driving end of the nail allows for adequate stability and fixation.^{1,5}

Improved anatomic fit

- ▶ Length dependent radius of curvature (.70-1.35m)^{2,3} and variable distal posterior bend designed for an improved anatomic fit. This may allow for both a standard entry and more posterior start point in periprosthetic fractures*.^{2,3,6}

Putting more options in your hands

- ▶ Hybrid locking configuration designed for fixation of distal and diaphyseal femur fractures.¹
- ▶ Additional indications for fractures involving osteopenic and osteoporotic bone, as well as periprosthetic fractures**.¹

Stability when and where you need it

Advanced Locking Screws

- ▶ Provide increased axial fracture stability in any 5mm round locking hole when the surgeon chooses.^{1,2}

IMN Locking Screws

- ▶ IMN locking screw design provides increased fatigue strength compared to competition.²

Condyle Screws

- ▶ Adjustable condyle screws allow for a range of 2mm longer or 5mm shorter than the actual condyle screw length for fragment compression.¹

Instrumentation made easy

Streamlined instrumentation platform

- ▶ One core basic tray that is used for T2 Alpha antegrade femur, retrograde femur and tibia designed to improve platform consistency and ease of use.¹

Guided proximal targeting devices for short and long nails

- ▶ Designed to provide reproducible locking, and reduce the total number of x-ray shots compared to freehand locking.^{4,7,8}

Static targeting arm

- ▶ Designed to provide stability and procedural ease during distal screw insertion.¹

A surgeon must always rely on his or her own professional clinical judgment when deciding whether to use a particular product when treating a particular patient. Stryker does not dispense medical advice and recommends that surgeons be trained in the use of any particular product before using it in surgery. The information presented is intended to demonstrate the breadth of Stryker product offerings. A surgeon must always refer to the package insert, product label and/or instructions for use before using any Stryker product. Products may not be available in all markets because product availability is subject to the regulatory and/or medical practices in individual markets. Please contact your Stryker representative if you have questions about the availability of Stryker products in your area.

Stryker Corporation or its divisions or other corporate affiliated entities own, use or have applied for the following trademarks or service marks: Stryker, T2 Alpha. All other trademarks are trademarks of their respective owners or holders. The products depicted are CE marked in accordance with applicable EU Regulations and Directives.

Content ID: T2-SS-14, 06-2021 Copyright © 2021 Stryker

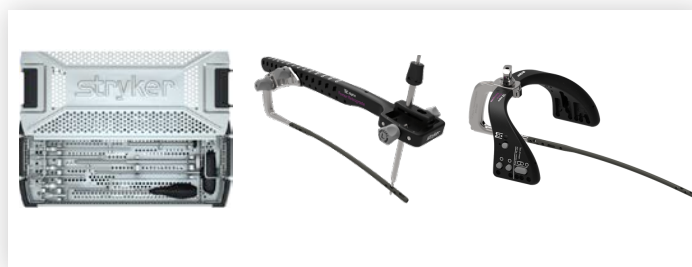
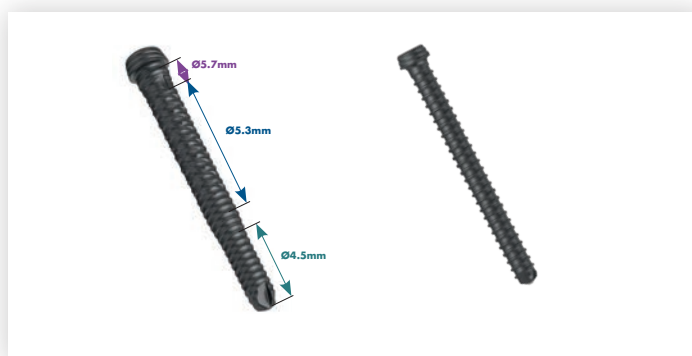

1. T2 Alpha Retrograde Femur Nailing System Surgical Technique T2-ST-37
2. T2-WP-6 Rev 1, 12-2019
3. Internal test report D0000082804
4. M.Ehlinger et al. Distal targeting device for long Gamma nail . Monocentric observational study. Orthopaedics and Traumatology:Surgery and Research. Vol 99-Issue 7. November 2013, Pages 799-804
5. Internal test report D0000084065
6. Internal test report D0000082802
7. T2-WP-8, 03-2019
8. Adam et al. External distal targeting device for safe insertion of distal locking screws when performing long Gamma Nail: Comparison with the freehand technique. Bone and Joint. Vol 94-B Supp XXXVII. 14. Sept. 2012

*for long nails only.

**see operative technique/IFU for complete set of indications.



Manufacturer:

Stryker Trauma GmbH
Prof.-Küntschers-Str. 1-5
24232 Schönkirchen
Germany

stryker.com