

# AxSOS 3<sup>®</sup> Titanium

## Distal Lateral Femur Locking Plate System

### Operative technique

Targeting instrumentation

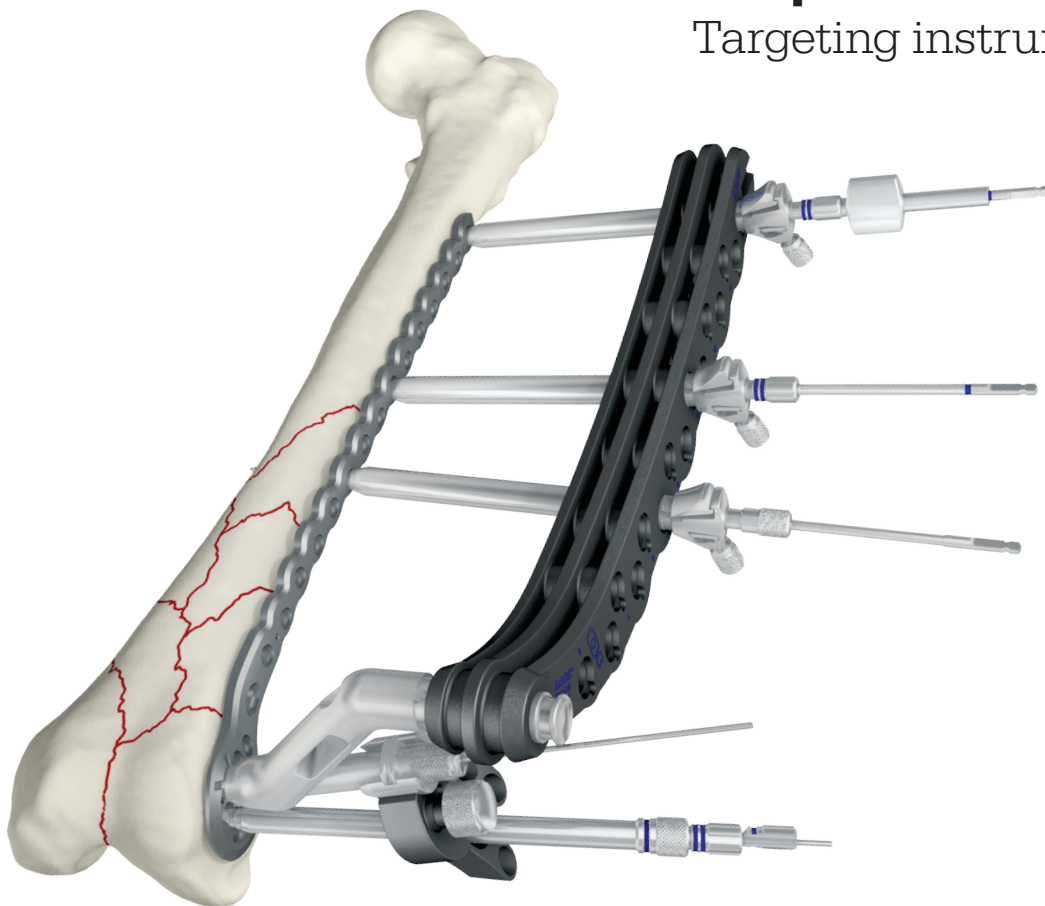

# AxSOS 3 Titanium

## Distal Lateral Femur Locking Plate System with targeting instrumentation

### Contents

Introduction. . . . .	3
Indications, precautions and contraindications. . . . .	4
Operative technique . . . . .	6
General guidelines . . . . .	6
Step 1 – pre-operative planning . . . . .	8
Step 2 – plate insertion handle assembly . . . . .	9
Step 3 – submuscular plate application . . . . .	10
Step 4 – primary plate fixation . . . . .	12
Step 5 – metaphyseal plate fixation . . . . .	15
Step 6 – shaft fixation . . . . .	18
5.0mm Variable Angle Extension Arm. . . . .	20
5.0mm Cable Plug . . . . .	24
Additional tips . . . . .	27
SPS Titanium – AxSOS 3 Titanium compatibility chart . . . . .	28

This publication sets forth detailed recommended procedures for using Stryker devices and instruments. It offers guidance that you should heed, but, as with any such technical guide, each surgeon must consider the particular needs of each patient and make appropriate adjustments when and as required. A workshop training is recommended prior to first surgery. All non-sterile devices must be cleaned and sterilized before use. Follow the instructions provided in our reprocessing guide (OT-RG-1).

Multi-component instruments must be disassembled for cleaning. Please refer to the corresponding assembly/disassembly instructions.

Please remember that the compatibility of different product systems has not been tested unless specified otherwise in the product labeling.

See instruction for use V15011, V15020, V15246 and V15013 for a complete list of potential adverse effects, contraindications, warnings and precautions.

The surgeon must discuss all relevant risks, including the finite lifetime of the device with the patient.

# Introduction

The AxSOS 3 Titanium Locking Plate System is intended for long bone fracture fixation. The system allows for the use of locking and non-locking screws in the metaphysis and the shaft. This operative technique contains a simple step-by-step procedure for the implantation of the distal lateral femur plate using the targeting instrumentation. Plates used in this operative technique guide: AxSOS 3 Titanium Distal Lateral Femur Plates. Please note that AxSOS 3 Titanium is made out of a titanium alloy (Ti6Al4V) and is not compatible with any stainless steel plates or screws.

Screws used in this Operative Technique Guide:

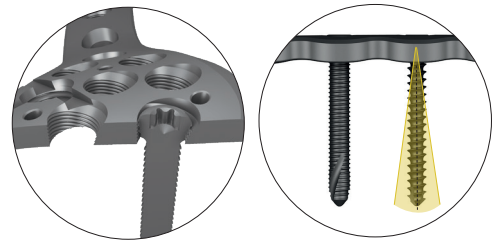
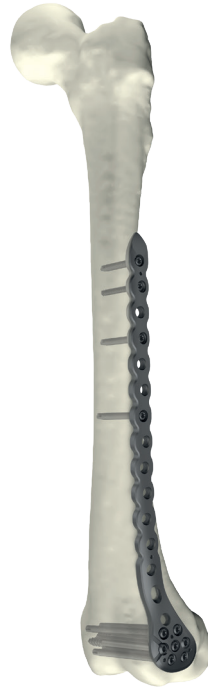

4.5mm cortical screw  
20° cone of angulation

cancellous    Locking    Cortical



SPS Titanium Basic Fragment  
ISO screws used with the AxSOS 3  
Titanium large fragment plates:

## Screw types

6.0mm  
cancellous  
full thread



6.0mm  
cancellous  
32mm thread



6.0mm  
cancellous  
16mm thread



4.5mm  
cortex  
shaft



4.5mm  
cortex  
screw



5.0mm  
locking  
screw



5.0mm  
periprosthetic  
screw



4.5mm  
cortex  
screw



All of the above AxSOS 3 Titanium screws have a T20 screw head interface. Please refer to the compatibility table on page 28 showing SPS and AxSOS 3 Titanium compatibility.

## 5.0mm blind screws    5.0mm cable plug

These optional inserts may be placed in empty universal screw holes.

The 5.0mm Cable Plug ensures a stable positioning of a cerclage cable on the plate and prevents slipping in oblique cable applications.

5.0mm



All of the above SPS Titanium Basic Fragment ISO screws have a Hex 3.5 screw head interface. Please refer to the compatibility table on page 28 showing SPS and AxSOS 3 Titanium compatibility.

## 5.0mm Variable Angle Extension Arm\*

The extension arm allows the variable angle placement of 4.0mm AxSOS 3 Titanium Locking Screws next to the plates, thus enabling the surgeon to go around an implant blocking the medullary canal.

# Indications, precautions and contraindications

## Indications

The AxSOS 3 Titanium is intended for long bone fracture fixation. Indications include:

- Diaphyseal, metaphyseal, epiphyseal, extra- and intra-articular fractures
- Non-unions and malunions
- Normal and osteopenic bone
- Osteotomies
- Periprosthetic fractures of the femur and proximal tibia

The AxSOS 3 Titanium Waisted Compression Plates are also indicated for fracture fixation of:

- Periprosthetic fractures
- Diaphyseal and metaphyseal areas of long bones in pediatric patients

The 4mm waisted compression plate indications also include fixation of the scapula and the pelvis.

## Precautions

### MRI Safety Information



#### **AxSOS 3 Titanium System (no periprosthetic indication)**

Non-clinical testing has demonstrated the Stryker AxSOS 3 Titanium System is MR Conditional.

A patient with these devices can be safely scanned in an MR system meeting the following conditions:

- Static magnetic field of 1.5T and 3.0T
- Maximum spatial field gradient of 3000 gauss/cm (30T/m)
- Maximum MR system reported, whole body averaged specific absorption rate (SAR) of 2 W/kg (Normal Operating Mode)

Under the scan conditions defined above, the Stryker AxSOS 3 Titanium System is expected to produce a maximum temperature rise of less than 7.1°C after 15 minutes of continuous scanning.

In non-clinical testing, the image artefact caused by the device extends approximately 32mm from the Stryker AxSOS 3 Titanium System when imaged with a gradient echo pulse sequence and a 3T MRI system.

#### **AxSOS 3 Titanium System (periprosthetic indication of the femur)**

Non-clinical testing has demonstrated the Stryker AxSOS 3 Titanium System is MR conditional. A patient with these devices can be safely scanned in an MR system meeting the following conditions:

- Static magnetic field of 1.5T and 3.0T
- Maximum spatial field gradient of 2000 gauss/cm (20T/m)
- Maximum MR system reported, whole body averaged specific absorption rate (SAR) of 2 W/kg (Normal Operating Mode)
- Scan time restriction: maximum 6 minutes of continuous scanning
- Only in combination with MR conditional Stryker hip implants

Under the scan conditions defined above, the Stryker AxSOS 3 Titanium System is expected to produce a maximum temperature rise of less than 8.9°C after 6 minutes of continuous scanning.

In non-clinical testing, the image artifact caused by the device extends approximately 45mm from the Stryker AxSOS 3 Titanium System when imaged with a gradient echo pulse sequence and a 3.0T MRI system.

### **CAUTION**

**The MRI safety information provided is based on testing which did not include supplementary devices. If there are supplementary devices (i.e. plates, screws, wires, prosthesis etc.) present in proximity to the System, this could result in additional MRI effects and the information provided above may not apply.**

# Indications, precautions and contraindications

## ⚠ CAUTION

**The AxSOS 3 Titanium 4.0mm and 5.0mm Waisted Compression Plates should not cross the growth plates of pediatric patients.**

## NOTICE

**SPS screws are also compatible with the AxSOS 3 Titanium Plates. Please refer to the compatibility table on page 28 showing SPS and AxSOS 3 Titanium compatibility. Please note that AxSOS 3 Titanium is made out of titanium alloy (Ti6Al4V) and is not compatible with any stainless steel plates or screws.**

## Intended use

AxSOS 3 Titanium is intended for long bone fracture fixation.

## Contraindications

The physician's education, training and professional judgement must be relied upon to choose the most appropriate device and treatment.

Conditions presenting an increased risk of failure include:

- Any active or suspected latent infection or marked local inflammation in or about the affected area
- Compromised vascularity that would inhibit adequate blood supply to the fracture or the operative site
- Bone stock compromised by disease, infection or prior implantation that cannot provide adequate support and / or fixation of the devices
- Material sensitivity, documented or suspected
- Obesity. An overweight or obese patient can produce loads on the implant that can lead to failure of the fixation of the device or to failure of the device itself

- Patients having inadequate tissue coverage over the operative site
- Implant utilization that would interfere with anatomical structures or physiological performance
- Any mental or neuromuscular disorder which would create an unacceptable risk of fixation failure or complications in postoperative care
- Other medical or surgical conditions which would preclude the potential benefit of surgery

See package insert for a complete list of potential adverse effects and contraindications. The surgeon must discuss all relevant risks, including the finite lifetime of the device, with the patient.

## NOTICE

**The only plates indicated for pediatric use are the 4.0mm and 5.0mm waisted compression plates.**

# Operative technique

## General guidelines

**Patient positioning:** Supine with option to flex the knee up to 60° over a leg support. Visualization of the distal femur under fluoroscopy in both the lateral and AP views is necessary.

**Surgical approach:** Standard lateral, modified lateral or lateral parapatellar approach.

### Reduction

Anatomical reduction of the fracture should be performed either by direct visualization with the help of percutaneous clamps, or alternatively a bridging external fixator to aid with indirect reduction to correct the length, rotation, recurvatum and varus-valgus.

Fracture reduction of the articular surface should be confirmed by direct visualization, or fluoroscopy.

Use K-wires and/or lag screws as necessary to temporarily secure the reduction. Typically, K-wires set parallel to the joint axis will not only act to hold and support the reduction, but also help to visualize/identify the joint.

Care must be taken that these do not interfere with the required plate and screw positions. Consideration must also be taken when positioning independent lag screws prior to plate placement to ensure that they do not interfere with the planned plate location or locking screw trajectories. If any large bony defects are present they should be filled by either bone graft or bone substitute material.

### Bending

In most cases the pre-contoured plate will fit without the need for further bending. However, should additional bending of the plate be required the table plate bender (ref 702900) should be used.

Plate contouring will affect the ability to use the targeting device for percutaneous screw placement and is therefore not recommended. However, should additional bending of the plate be required (generally at the junction from the metaphysis to the shaft) the table plate bender (ref 702900) should be used.

If for any reason the plate needs intra-operative contouring, it is recommended to perform shaft fixation using the conventional screw insertion technique without the use of the targeting device.

### NOTICE

**When using a sub-muscular technique, please refer to the relevant section on page 10.**

# Operative technique

## General guidelines

### Screw measurement

There are four options to obtain the proper screw length as illustrated below (fig. 1-5). The screw scale (ref 703587) should always be used with the assembled tissue protection sleeve and the drill guides.

### Correct screw selection

Select a screw approximately 2mm–3mm shorter than the measured length to avoid screw penetrations through the medial cortex in metaphyseal fixation.

Add 2mm–3mm to measured length for optimal bi-cortical shaft fixation.

### Measurement options

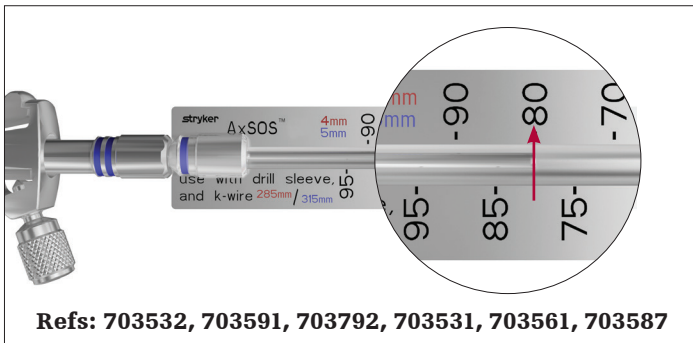

Fig. 1: Measure off K-wire

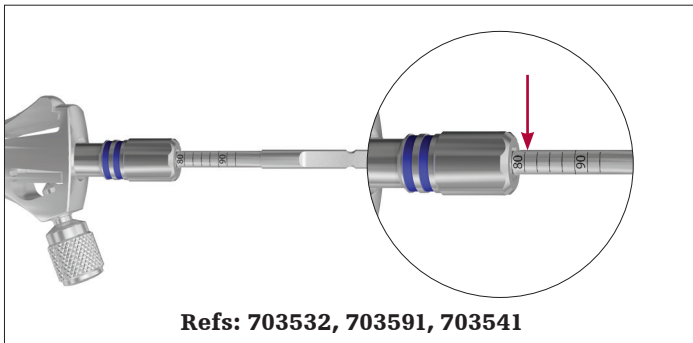

Fig. 2: Measure off calibration



Fig. 3: Measure off measure gauge

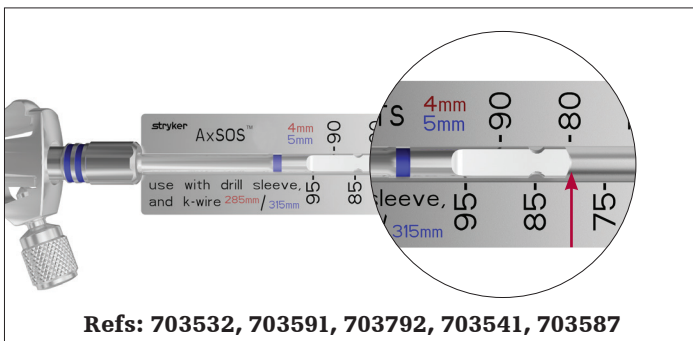

Fig. 4: Measure off drill end

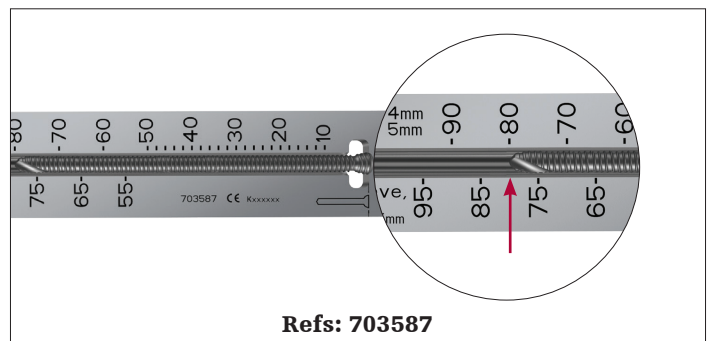

Fig. 5: Screw length control

# Operative technique

## Step 1 – pre-operative planning

Use of the X-ray template (ref 981204) in association with X-rays can assist in the selection of an appropriately sized implant (fig. 6).

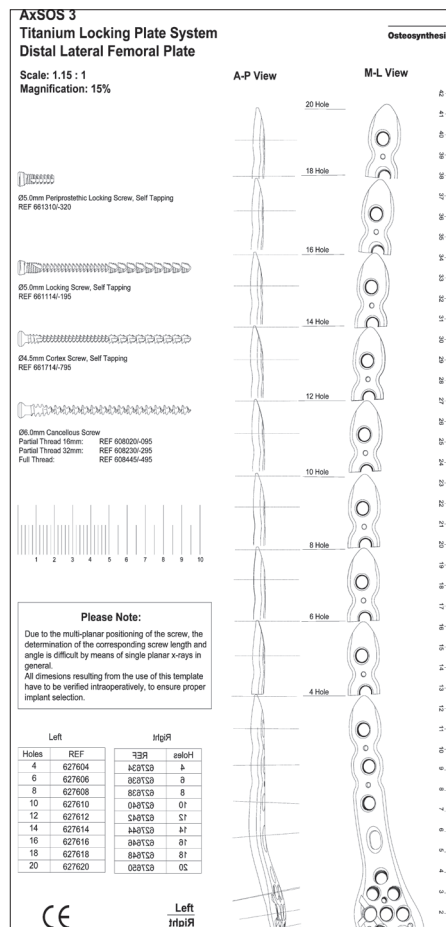

Fig. 6



# Operative technique

## Step 2 – plate insertion handle assembly

Thread the connection pin (ref 703521) to the plate using the hex screwdriver 3.5mm / 4.3mm (ref 703537) (fig. 7a).

Connect the adaptor nut (ref 702977) to the plate adaptor (ref 703523 left / 703522 right) and slide the plate adaptor over the connecting pin with the connecting part for the targeting arm pointing to the anterior curvature of the plate. After correct engagement of the alignment teeth in the corresponding grooves in the plate, secure the plate adaptor by tightening the adaptor nut with the same hex screwdriver (fig. 7b). It is recommended to temporarily apply the corresponding targeting arm to check the correct alignment of the targeting device and plate.

Insert a drill (ref 703541) through the assembled tissue protection sleeve and drill sleeve (refs 703532, 703792) into the relevant threaded plate hole prior to plate application.

The targeting arm can now be removed again.

The plate insertion handle (ref 702978) can now be attached to help facilitate plate positioning and sliding of longer plates sub-muscularly (fig. 7).

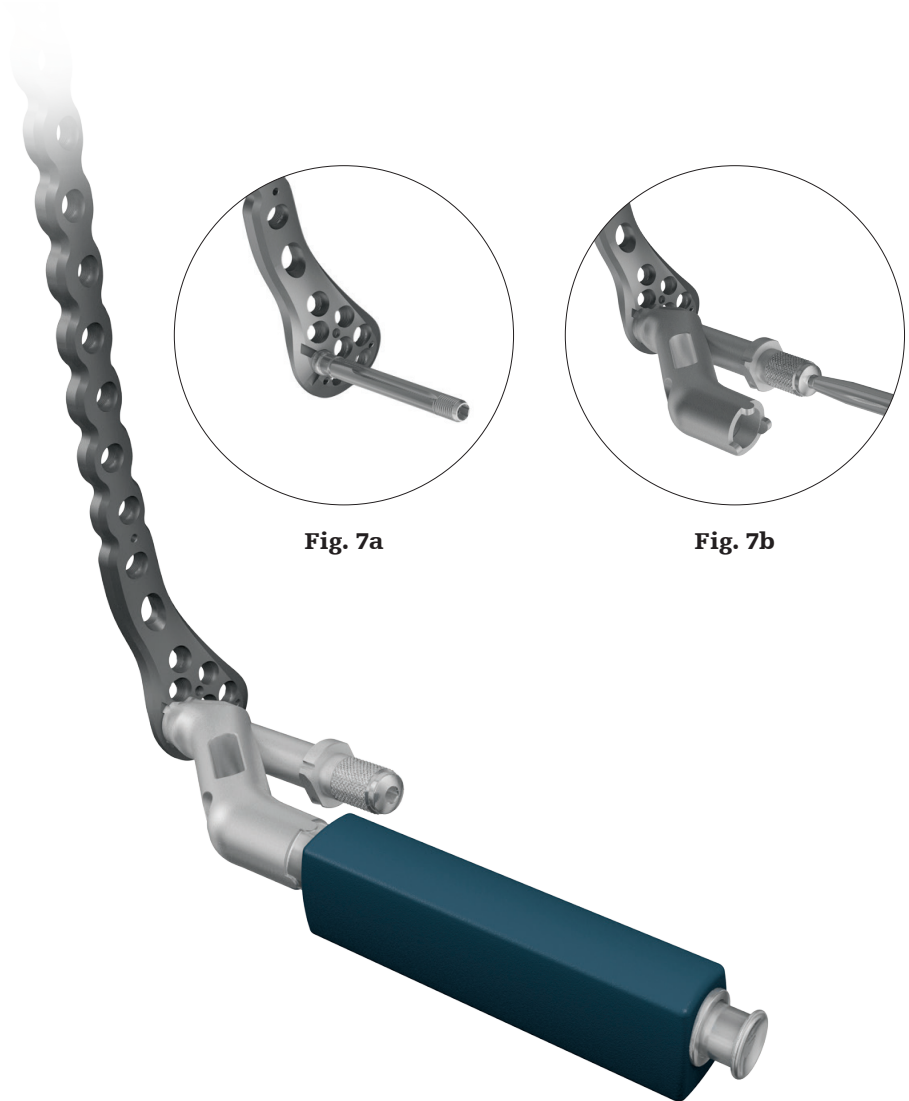

Fig. 7a

Fig. 7b

Fig. 7

# Operative technique

## Step 3 – submuscular plate application

### Patient position

Place the patient in the supine position on a radiolucent table to allow visualization from knee to hip. One may need a small bump under the ipsilateral hip to correct the proximal leg external rotation. Use the leg elevator to provide leg support and knee flexion to allow fluoroscopy of the femur in both the AP and lateral views. Prep and drape the leg circumferentially extending proximal to the hip to allow proximal extension of the surgical incision if needed. A sterile tourniquet may be useful if treating a distal femur fracture.

### Surgical approach

Surgeon may use an anterolateral or lateral parapatellar approach, depending on the fracture pattern. Surgical Exposures in Orthopaedics: The Anatomic Approach, 4th ed. Hoppenfeld et al. lateral/anterolateral surgical approach is commonly used for OTA A, B, and “simple” C (C-1 / C-2) fracture patterns. The skin incision starts at Gerdy’s tubercle and extends proximally to a direct lateral incision. The iliotibial band is incised in the same pattern. The joint capsule is then incised if intra-articular reduction needs to be performed or confirmed.

Lateral para-patellar surgical approach is used for OTA C fractures with significant intra-articular disruption.

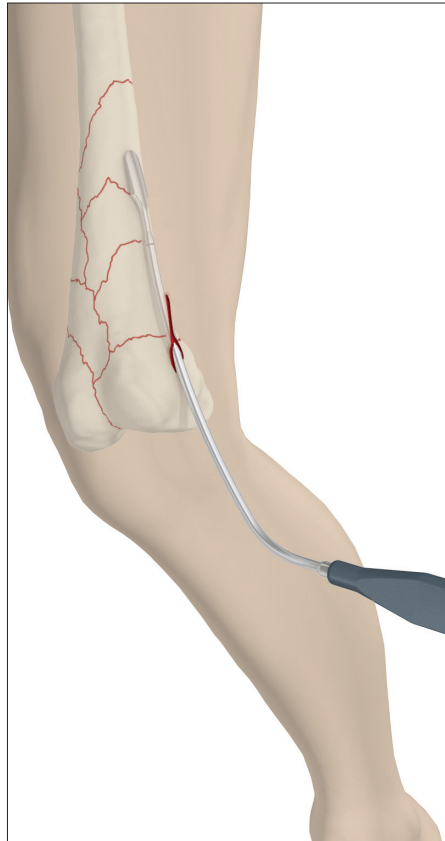

Fig. 8

The skin incision starts just lateral to the tibial tuberosity and extends proximally on the lateral border of the patella. The incision can then traverse to a lateral position. A capsulotomy is performed at the lateral border of the patella and the patella mobilized medially to allow joint visualization.

The soft tissue elevator (ref 702782) has been designed to create a pathway for the plate (fig. 8). The plate has a special rounded and tapered end, which further allows for smooth insertion under the soft tissue.

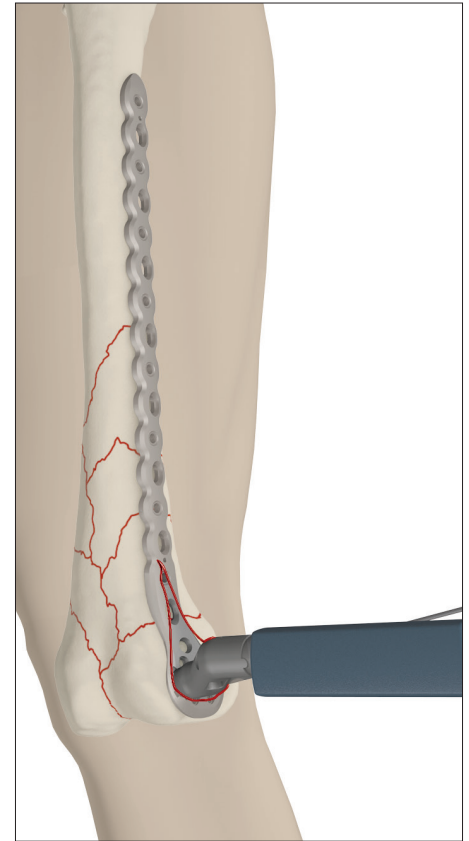

Fig. 9

After the appropriate surgical exposure, based on fracture pattern, is complete (lateral/anterolateral/lateral parapatellar as described above) obtain fracture reduction.

Fracture reduction, once obtained, can be held provisionally with K-wires and/or reduction forceps. External fixation may also be utilized to help with axial, angular, and rotational control across the fracture.

# Operative technique

Confirm anatomic reduction of the articular surface via direct visualization, palpation, and / or fluoroscopy. (Skeletal trauma, 2nd ed., master techniques in orthopaedic surgery: fractures). Position the plate on the lateral surface of the femur by using the insertion handle to slide the plate proximally in a sub-muscular fashion (fig. 9, page 10). As you insert the plate, use the plate to feel the femur to confirm a direct lateral position, not anterior or posterior to the femoral shaft.



**Fig. 10**

## NOTICE

**Avoid plate insertion through the muscle to avoid intra-muscular vessel disruption.**

**Avoid periosteal disruption while inserting the plate to help preserve bone blood supply.**

**Prior to any screw fixation, confirm that the plate placement is correct. Confirm that the capsule edges and iliotibial band are not trapped under the plate, as these layers will need to be available for layered wound closure. Confirm that the plate is sub-muscular, not intra-muscular.**

The proper position is achieved when the distal and anterior margin of the plate is approximately 5mm–10mm from the articular surface (fig. 9, page 10). This helps to ensure that the most distal locking screws are directly supporting the joint surface.

In addition, it is recommended to insert plate end markers (ref 703530) into the appropriate holes of the targeting arm before plate application.

This will assist in locating the plate end and holes designated for locked fixation during the entire procedure (fig. 10).

# Operative technique

## Step 4 – primary plate fixation

A K-wire Ø2.0mm x 315mm (ref 703561) can now be inserted through the cannulation of the adaptor nut and the plate adaptor to help secure the plate to the bone (fig. 11).

Precise alignment of the K-wire can be achieved by using a K-wire sleeve (ref 703531) through the cannulation of the plate adaptor. For increased provisional plate fixation, it is also recommended to insert a K-wire in one of the distal plate K-wire holes.

This, in addition to other independently placed K-wires can help to support articular surface fragments.

Remove the handle for insertion by pressing the metal button at the top of the handle.

At this point, alignment of the plate to the shaft of the femur should be checked by fluoroscopy both on the AP and lateral projections.

Attach the correct aiming block (ref 703527 left / 703526 right) to the plate adaptor (fig. 12a). Ensure that the aiming block is properly seated on the adaptor shaft by a 90° rotation on the plate adaptor and secured with the aiming block screw (ref 703597) (fig. 12b).

Using the aiming block tissue protection sleeve (ref 703533) together with the drill sleeve (ref 703792) and the trocar (ref 703524), the drill sleeve can now be inserted into either

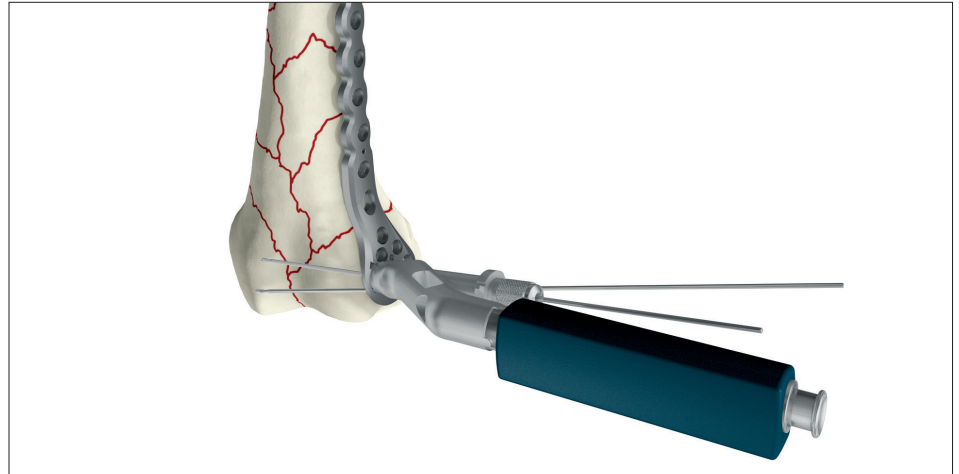

Fig. 11

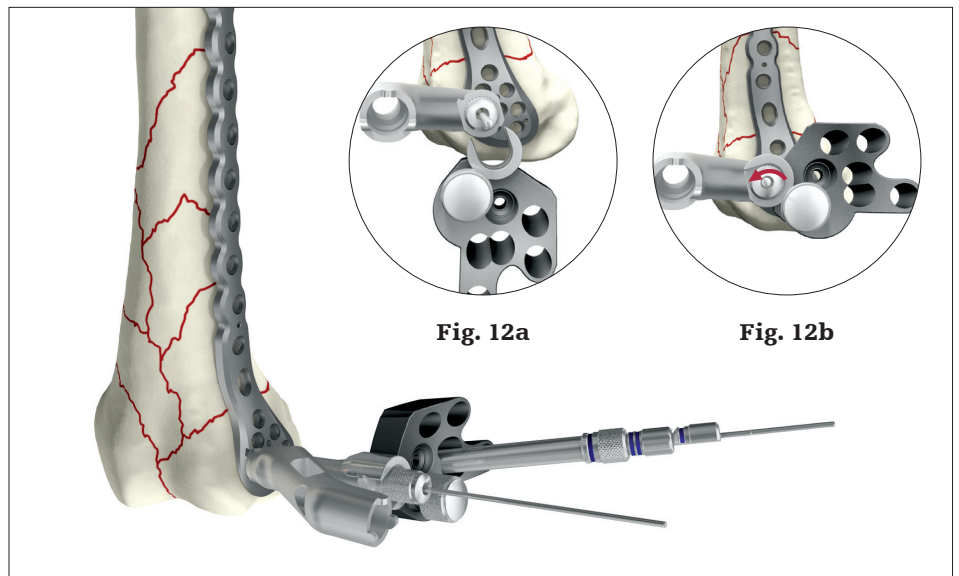

Fig. 12

one of the two distal universal holes of the metaphyseal portion of the plate.

Ensure that the drill sleeve is properly seated in the thread of the plate hole.

Remove the trocar, replace it with the K-wire sleeve (ref 703531) and insert a Ø2.0mm x 315mm K-wire (ref 703561) (fig. 12).

This wire should be parallel to the joint line to assure proper alignment of the distal femur. The K-wire indicates the position of a later placed screw that shows its relation to the joint surface and also confirms the screw will not be placed intra-articularly.

Using fluoroscopy, the position of this K-wire can be checked by manipulating the plate until the optimal position is achieved and the plate is correctly positioned.

## Operative technique

Correct proximal plate placement should also be re-confirmed at this point to make sure the plate shaft is properly aligned over the lateral surface of the femoral shaft. If the distal and axial alignment of the plate cannot be achieved, the K-wires should be removed, the plate re-adjusted and the above procedure repeated until both the distal K-wires and the plate are in the desired position.

### NOTICE

**Do not remove K-wires as a loss of plate position could result.**

The proximal end of the plate must now be secured using the most proximal hole of the shaft.

Attach the correct targeting arm to the plate adaptor. The right targeting arm (ref 703528) is used for the right leg and the left targeting arm (ref 703529) is used for the left leg.

Mark the skin at the most proximal shaft hole using the tissue protection sleeve (ref 703532) and make a small incision. Insert the trocar with sharp tip (ref 703525) into the tissue protection sleeve (ref 703532) and manipulate the assembly through the targeting arm and the stab incision until the tip of the trocar is in contact with the plate.

Push the tissue protection sleeve further into the hole until the locking notches of the tissue protection sleeve fully engage in the corresponding groove

in the targeting arm (details see also step 6 shaft fixation).

Essentially, this will securely lock the tissue protection sleeve in the targeting arm.

Ensure that the sleeve fixation screw is orientated posterior as displayed on the targeting arm.

Remove the trocar and replace it with a drill sleeve (ref 703792) and trocar Ø4.3mm (ref 703524) and manipulate the assembly into the plate hole.

Ensure that the drill sleeve is fully engaged in the thread of the plate hole to create a stable



Fig. 13a

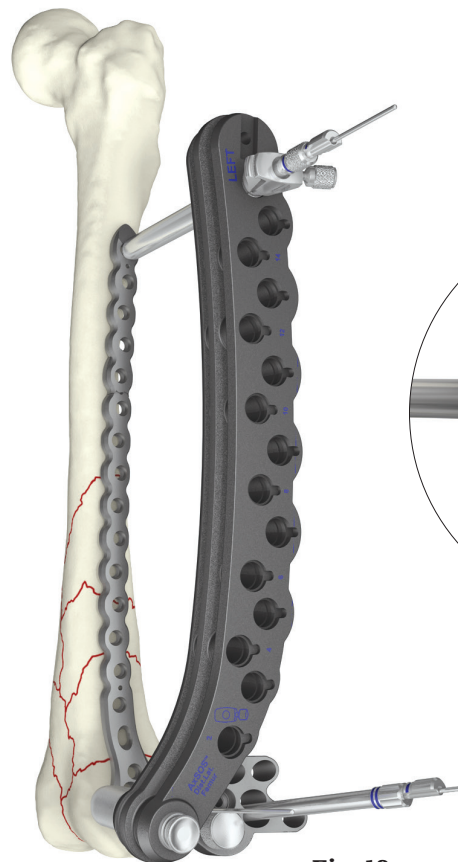

Fig. 13

construct between the targeting arm and the plate, providing sufficient stability for accurate screw targeting.

Secure the drill sleeve by tightening the sleeve fixation screw. Remove the trocar.

A Ø2.0mm x 315mm K-wire (ref 703561) can now be inserted using the K-wire sleeve (ref 703531) (fig. 13).

Alternatively, the Ø4.3mm calibrated drill (ref 703541) can be inserted bi-cortically. Leave the drill bit in place for primary proximal plate stabilization (fig. 13a).

# Operative technique

If desired, the plate can be pushed to the bone by using the frame fixator (ref 703545) instead of the drill or K-wire.

Remove the flat butterfly-nut of the fixator. The self-drilling, self-tapping tip of the frame fixator pin should be inserted bi-cortically through the drill sleeve (ref 703792) (fig. 14). Use fluoroscopy to confirm bi-cortical purchase when necessary.

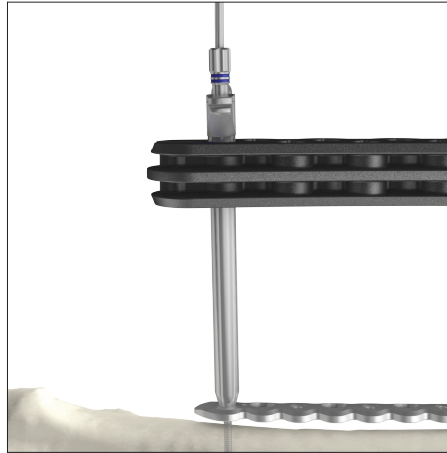

Fig. 14



Fig. 15

## ⚠ CAUTION

When inserting the pin by power, make sure to use a low-speed to avoid significant temperature increase which can lead to bone necrosis. Unlock the drill sleeve by loosening the sleeve fixation screw, and re-attach the flat butterfly-nut over the threaded part of the pin and turn the nut until the plate is in the desired position on the bone (fig. 15).

## NOTICE

When using plates with 10 holes or longer, it is recommended to insert one or two additional tissue protection /drill sleeve assemblies in holes in the middle positions of the plate shaft. This will help to compensate for plate deformity that might occur using cortical screws to push the plate against the bone.

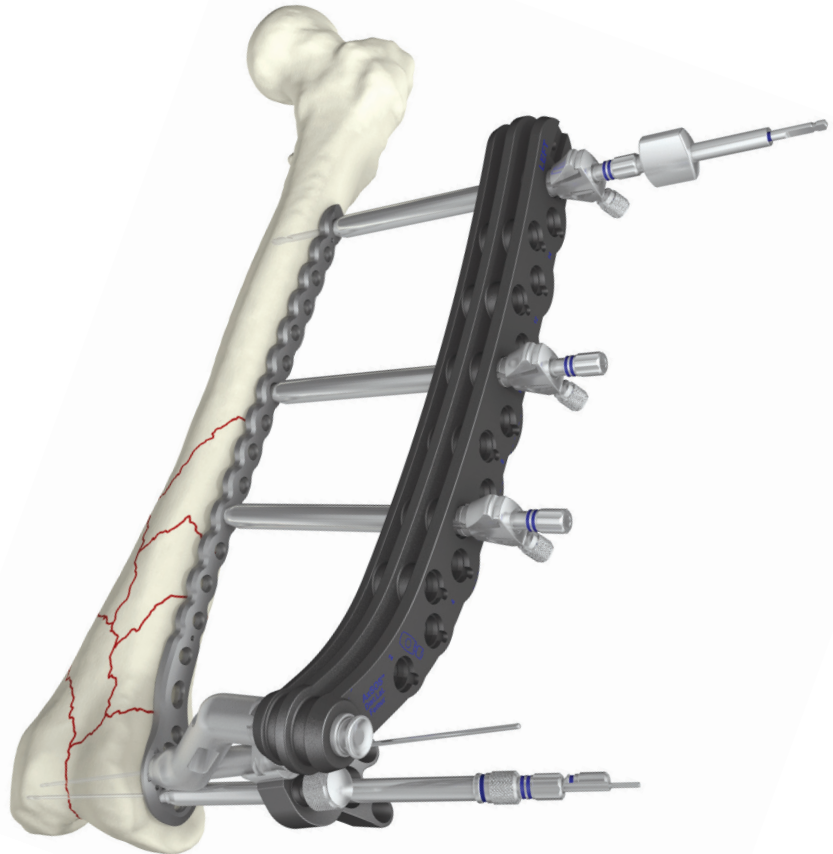

Fig. 16

Do not use the sleeve fixation screw (ref 703591) to fix the locking drill sleeve to the tissue protection sleeve.

This will allow the sleeve and the plate to contour to the bone without compromising the accuracy of the locking screws (fig. 16).

# Operative technique

## Step 5 – metaphyseal plate fixation

Locking screws cannot act as lag screws. Should an interfragmentary compression effect be required for metaphyseal fragments, a partially threaded Ø6.0mm cancellous screw must first be placed in any of the metaphyseal plate holes prior to the placement of any locking screws.

Freehand placement of the screw(s) can be performed using the freehand tissue protection sleeve (ref 703546) together with the drill sleeve Ø3.2mm (ref 703535) (fig. 17).

It is recommended to use the most posterior metaphyseal hole (second screw row) by placing the freehand tissue protection sleeve in the recess (see arrow) at the posterior aspect of the aiming block (fig. 18). This screw trajectory helps to avoid interference with any of the later inserted screws in the metaphysis. Use the calibrated drill Ø3.2mm (ref 703542) and drill the core hole to the appropriate depth. It is recommended to drill under fluoroscopy control to avoid interference with preset K-wires. Manipulate the K-wires as necessary. The screw length may be directly read off the calibrated drill or using the screw scale (ref 703587) as described under measurement options on page 7.

Over-drill the first cortex using the cortical opener Ø4.5mm (ref 703543) through the tissue protection sleeve.

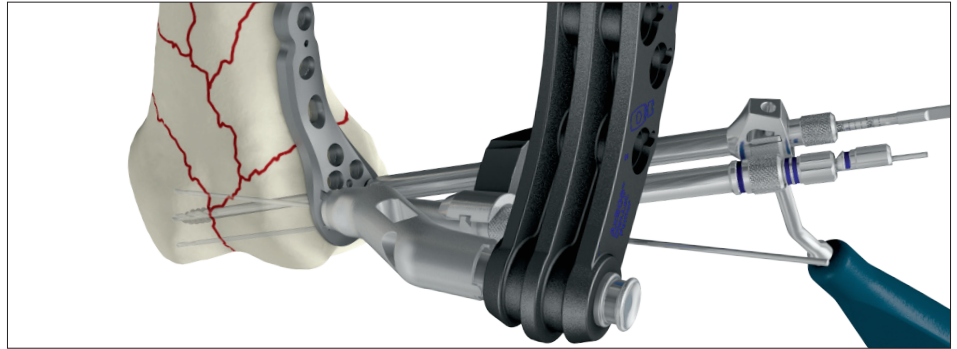

Fig. 17

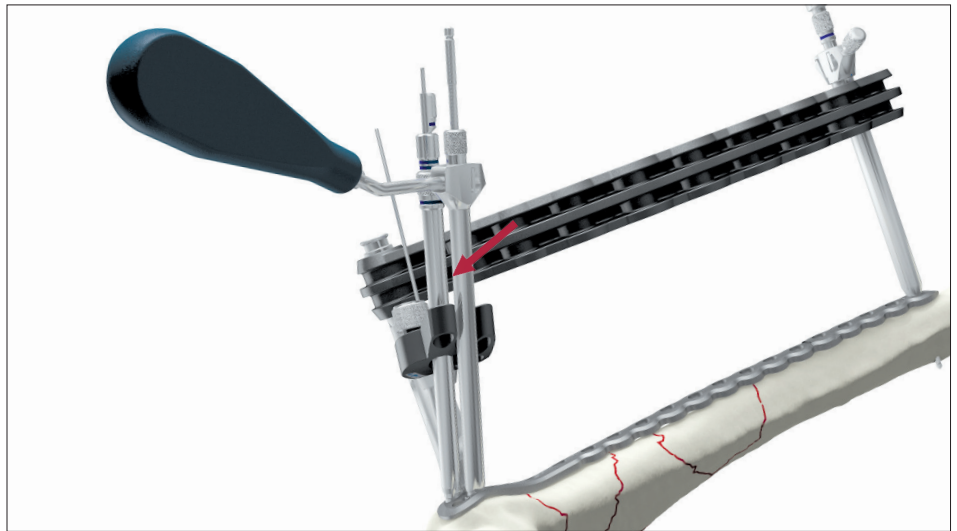

Fig. 18

In hard cortical bone, it is advised to use the cancellous tap Ø6.0mm (ref 703555) before screw insertion.

The screw can then be inserted through the tissue protection sleeve using the screwdriver T20 (ref 703539) or screwdriver bit T20 (ref 703540). Additional non-locked screws can be inserted in any metaphyseal holes using the same technique through the guiding holes in the aiming block.

When using the aiming block (ref 703527 left / 703526 right) the tissue protection sleeve (ref 703533), the drill sleeve

(ref 703535) and the calibrated drill Ø3.2mm (ref 703542) should be used. Ø4.5mm cortical screws can be used alternatively.

Care must be taken that these screws do not interfere with the given locking screw trajectories. The usage of the aiming block will aid in preventing screw collision.

# Operative technique

Locking Fixation of the metaphyseal portion of the plate can now be started in the remaining plate holes. Remove the preset K-wire and K-wire sleeve in the posterior plate hole.

Using the calibrated drill bit Ø4.3mm (ref 703541) together with the soft tissue protection sleeve (ref 703533) and the drill sleeve (ref 703792) drill the core hole for the locking screw.

Stop drilling once the drill tip touches the medial cortex to ensure that the screw tip will not protrude. It is recommended to use multiple fluoroscopic views which may be necessary to ensure proper location and depth of the drill. The screw length can be determined with a direct read off the calibration of the drill or any other measurement option as described on page 7.

The drill and the drill sleeve should now be removed and the correct length of the Ø5.0mm locking screw is inserted using the screwdriver T20 (ref 703539), or screwdriver bit T20 (ref 703540) (fig. 19).

The screw is near its final seating position when the blue marking around the shaft of the screwdriver approaches the end of the tissue protection sleeve (fig. 20). Locking screws should initially be inserted manually to ensure proper alignment.

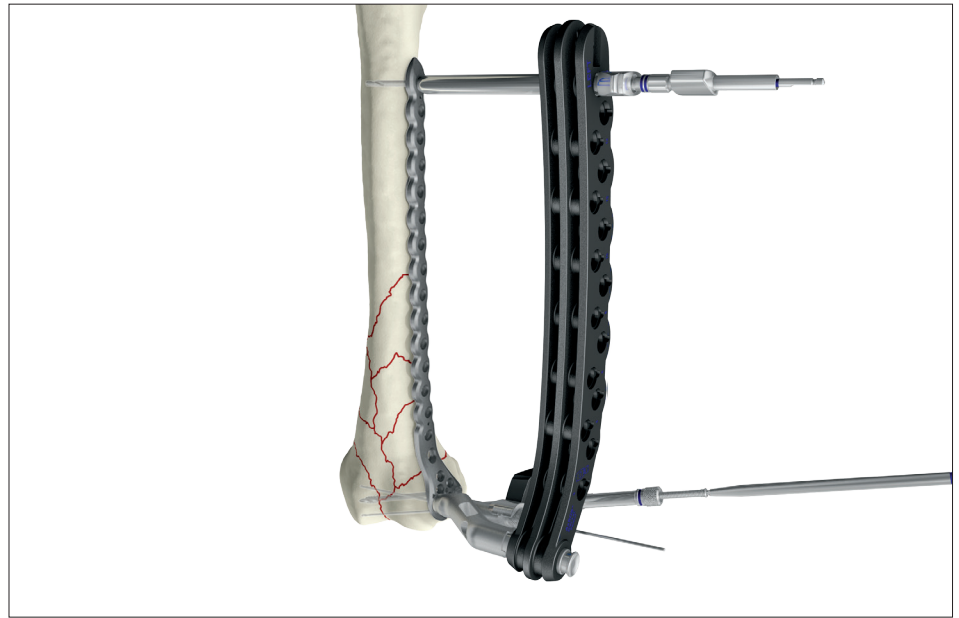

Fig. 19

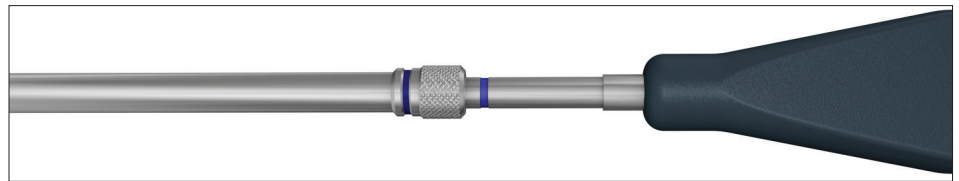

Fig. 20

## NOTICE

- **Ensure that the screwdriver tip is fully seated in the screw head, but do not apply axial force during final tightening**
- **If inserting locking screws under power, make sure to use a low speed drill setting to avoid damage to the screw /plate interface and bone necrosis**



## Operative technique

Final tightening of locking screws should always be performed manually using the torque limiter (ref 702750) together with the screwdriver bit T20 (ref 703540) and the T-handle (ref 702430) (fig. 21). This helps prevent over-tightening of locking screws, and also ensures that these screws are tightened to a torque of 4.0Nm. The device will click when the torque reaches the appropriate tightening torque (4.0Nm).

### ⚠ CAUTION

**The torque limiters require routine maintenance. Refer to the instructions for use of torque limiters (ref V15020).**

The remaining metaphyseal locking screws are inserted following the same technique. To ensure maximum stability, it is recommended that all six metaphyseal universal holes are filled with locking screws of the appropriate length (fig 22). The targeter attachment hole accepts only non-locking screws.

### NOTICE

**In the extreme event of broken or stripped screws, the Stryker implant extraction set (literature number IES-ST-1) includes a variety of removal instruments.**

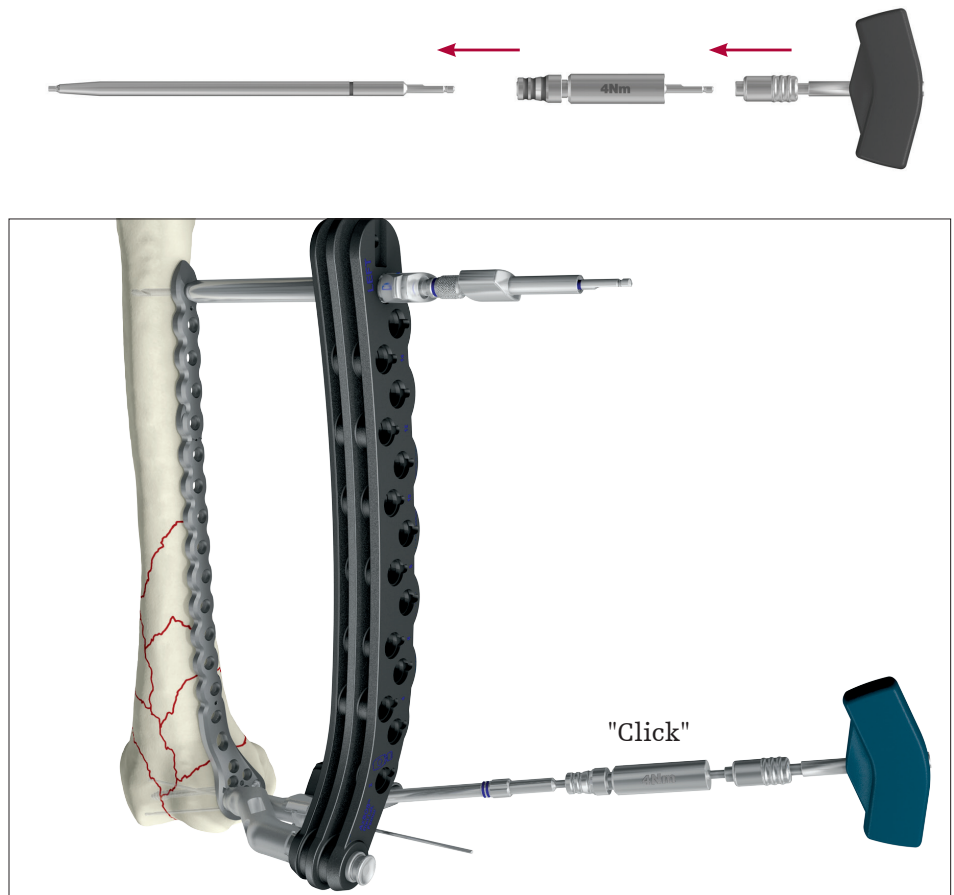

Fig. 21

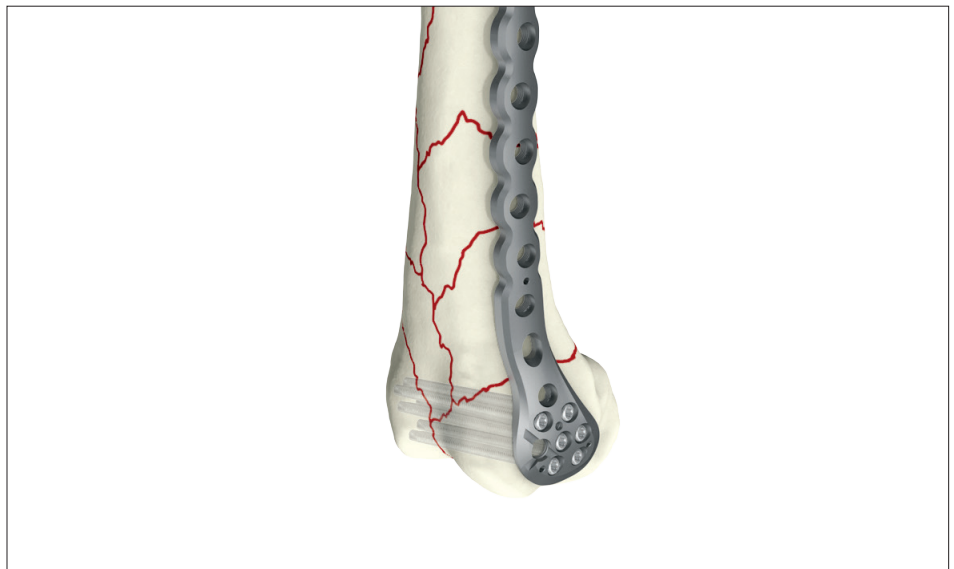

Fig. 22

# Operative technique

## Step 6 – shaft fixation

### A) Non-locking screws

#### **⚠ CAUTION**

**Non-locked cortical screws in the shaft must be placed prior to any locking screws.**

Mark the chosen shaft hole using the tissue protection sleeve and make a small incision. Insert the tissue protection sleeve (ref 703532) together with the trocar with sharp tip (ref 703525) until the tip is in contact with the plate (fig. 23). Push the tissue protection sleeve further until you hear a click, confirming that the sleeve has snapped into position (fig. 24). Remove the trocar with sharp tip and replace it with the Drill sleeve (ref 703535). Insert the trocar Ø3.2mm (ref 703536) and manipulate the assembly into the plate hole. Lock the drill sleeve with the sleeve fixation screw (ref 703591) and remove the trocar (fig. 25). The calibrated drill Ø3.2mm (ref 703542) is then used to drill the core hole for the Ø4.5mm cortical screw (fig. 26).

Drill through both cortices for bi-cortical screw fixation. The screw length can be determined with a direct read off the calibration of the core drill, or any other measurement option as described on page 7.

If the screw is set in a lag function, remove the drill sleeve after core hole drilling and

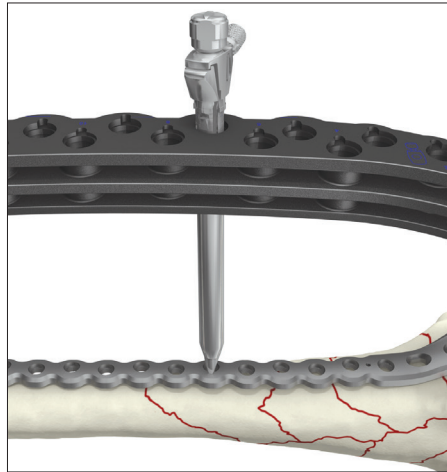

Fig. 23

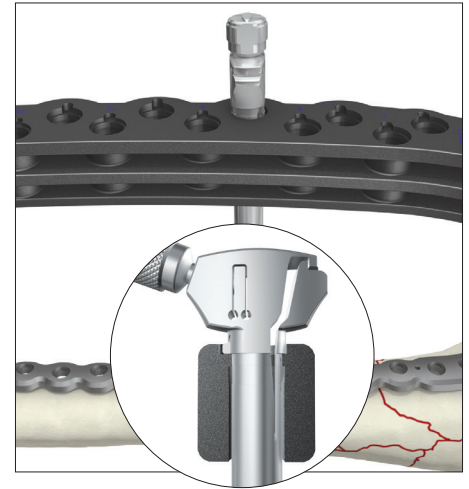

Fig. 24

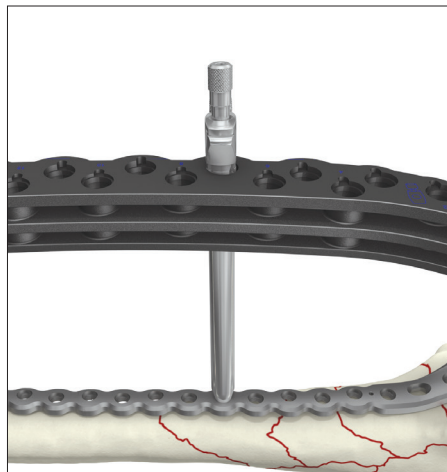

Fig. 25

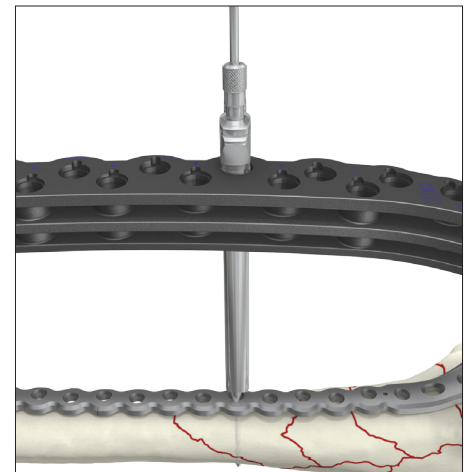

Fig. 26

over-drill the first cortex using the cortical opener Ø4.5mm (ref 703543).

The appropriate size of the cortical screw is inserted using the T20 screwdriver (ref 703539) or the screwdriver bit (ref 703540) for power insertion (fig. 27). In hard cortical bone, it is advised to use the cortical tap Ø4.5mm (ref 703551) before screw insertion. Repeat the same procedure for other chosen non-locked shaft holes.

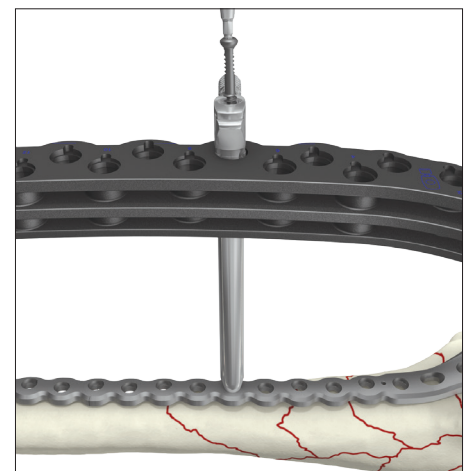

Fig. 27

# Operative technique

## B) Locking screws

Ø5.0mm locking screws can be placed in any shaft hole except the oval hole and the most proximal metaphyseal hole at the junction from the metaphysis to the shaft part. For the placement of these screws, follow the same procedure detailed in step 6A) above with the appropriate instrumentation for locking screws, outlined as follows:

### NOTICE

**If an uncommonly hard cortex is identified during pre-operative planning, pre-tap both cortices using the tap for locking screws (ref 703554) before screw insertion. Final plate and screw positions are shown in figures 28–30.**

- **Drill sleeve Ø4.3mm (ref 703792)**
- **Trocar Ø4.3mm (ref 703524)**
- **Calibrated drill Ø4.3mm (ref 703541)**
- **Screwdriver T20 (ref 703539)**
- **Screwdriver bit T20 (ref 703540)**
- **Tap Ø5mm locking (ref 703554)**
- **4.0Nm torque limiter, AO fitting (ref 702750)**

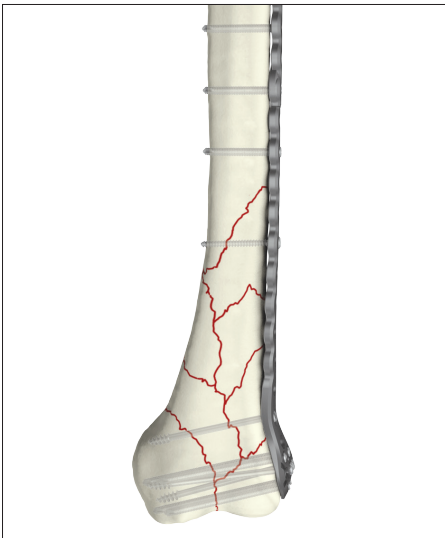
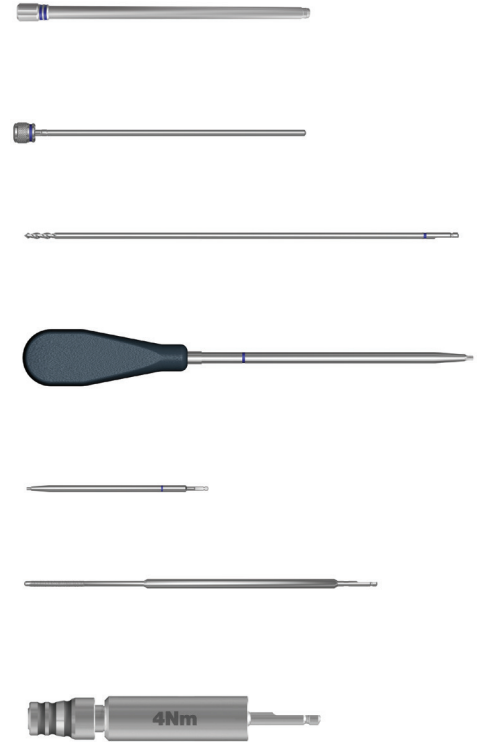

Fig. 28



Fig. 29

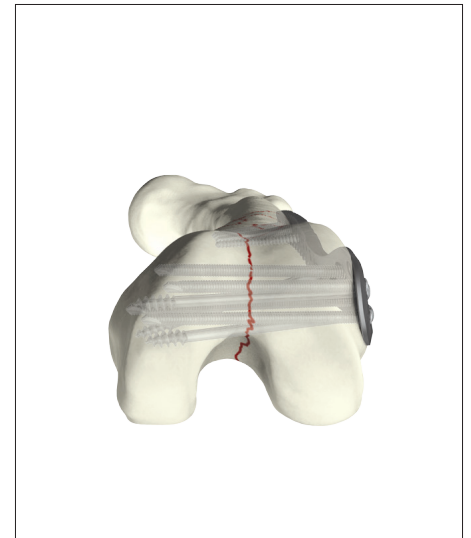

Fig. 30

# 5.0mm Variable Angle Extension Arm\*

The 5.0mm variable angle extension arm\* (ref 991088S, referred to as extension arm), made out of Titanium /CoCr, can be inserted into 5.0mm universal holes of the broad or narrow AxSOS 3 Titanium Compression plates or in the universal holes of the diaphyseal area of the AxSOS 3 Titanium Distal Lateral Femur Plates. The extension arm allows the variable angle placement of 4.0mm AxSOS 3 Titanium Locking Screws next to the plates, thus enabling the surgeon to go around an implant blocking the medullary canal. To insert an extension arm follow the next steps. The extension arm can be placed manually or optionally with the orange 4.0mm drill sleeve as placement aid. In this case fix and tighten the orange 4.0mm drill sleeve by hand in the polyaxial mechanism (fig. 31).



Fig. 31



Fig. 32

## NOTICE

**Hole number 17 in long AxSOS 3 Titanium Distal Lateral Femur Plates is designed slightly in an oblique way to avoid conflicting protection sleeves with the optional targeting instrumentation.**

**Hole number 17 cannot be used together with the extension arm – see picture on the right. The universal holes in the metaphyseal part of AxSOS 3 Distal Lateral Femur Plates and hole number one (oblong, non-locking) can't be used together with an extension arm (fig. 32).**



T15 screwdriver bit 705015

2.5Nm torque limiter 702760

T-handle 702427

Insert the 4.0mm blind screw (packaged together with the extension arm) using the T15 screwdriver from the 4.0mm AxSOS 3 Titanium System (fig. 32).

\* This product is not CE marked in accordance with applicable EU regulations and directives. Stryker is not marketing or distributing this product in the EU. Any reference to this product is for presentation purposes only.

## 5.0mm Variable Angle Extension Arm

While tightening the 4.0mm blind screw adjust the rotation of the extension arm and hold it in place if necessary. Final tighten with the 2.5Nm torque limiter. At least one click shall be emitted (fig. 33).

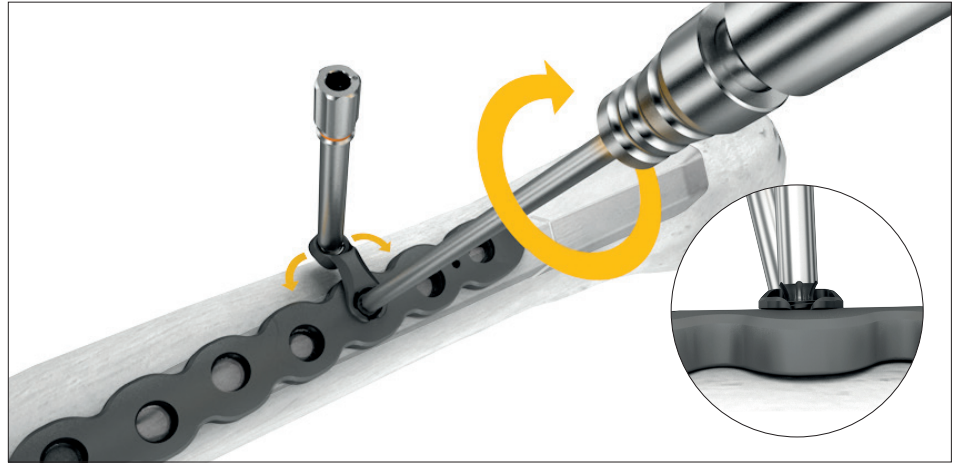

Fig. 33

Use the drill sleeve in the polyaxial hole and choose the desired angle for the screw placement. The cone allows for a +/- 15 degree cone of angulation (fig. 34).

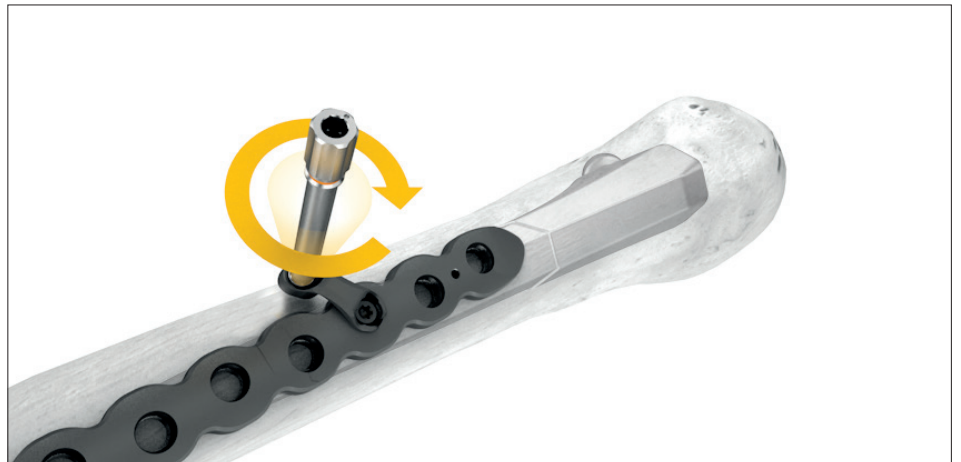

Fig. 34

In the event of placing a K-wire use it together with the K-wire sleeve (fig. 35). Tighten the drill sleeve by hand.

### NOTICE

**Be aware of the different diameter and flexibility between K-wire, drill bit and 4.0mm locking screws.**

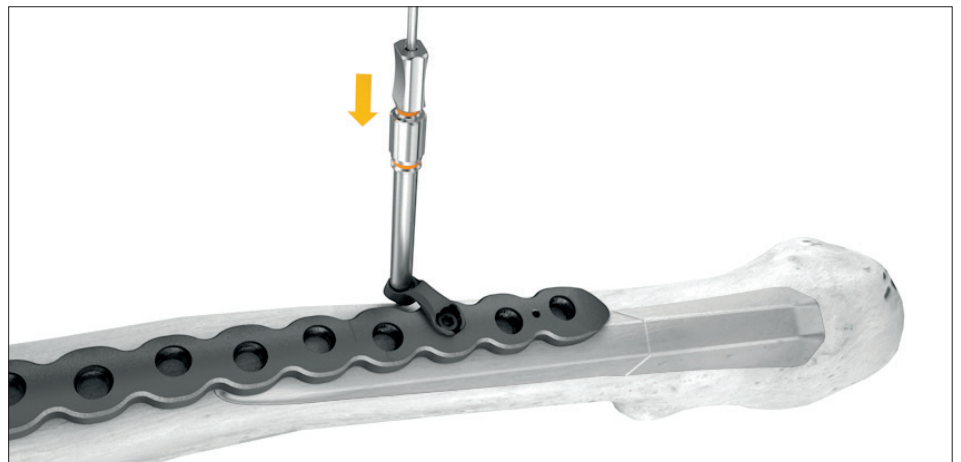

Fig. 35

## 5.0mm Variable Angle Extension Arm

Remove the K-wire and the K-wire sleeve and drill with the 3.1mm drill bit (fig. 36). Measure by reading off the drill bit. Alternatively remove the drill sleeve and measure with the depth gauge. Place an appropriate 4mm locking screw.



Fig. 36

Insert and final tighten the 4mm locking screw with the 2.5Nm torque limiter. At least one click shall be emitted (fig. 37).



Fig. 37

### **⚠ CAUTION**

**In case of mixing non-locking and locking screws always follow the principle of "lag before lock".**

**When using the variable angle extension arm consider bending the femur plate or compression plate for appropriate bone support.**

**To limit the risk of weakening the bone avoid too many screws in a concentrated area (fig. 38, 39). Bi-cortical purchase offers better stability and limits the risk of weakening the bone.**

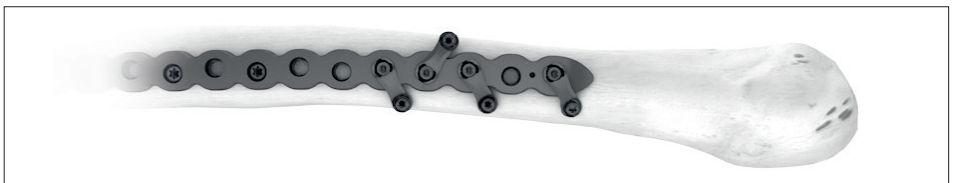

Fig. 38

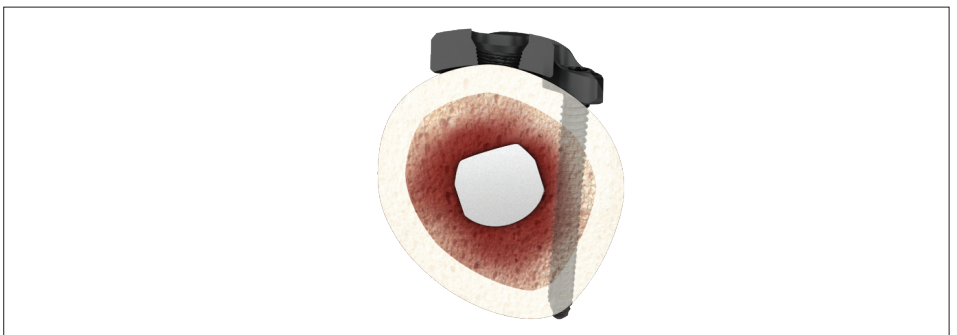

Fig. 39

## 5.0mm Variable Angle Extension Arm

### Extension arm removal

Toggle the extension arm for disassembling by hand or use standard pliers.

**⚠ CAUTION**

**The variable angle extension arm is a single-use, single application device. If the device has been previously used intraoperatively, discard the device and use a new extension arm.**

# 5.0mm Cable Plug

The 5.0mm Cable Plug (ref 661002S) is designed to be used in combination with the 5.0mm AxSOS 3 Titanium System. It is used in combination with cobalt chrome cables of 2mm diameter.

The 5.0mm Cable Plug ensures a stable positioning of a cerclage cable on the plate and prevents slipping in oblique cable applications.

## NOTICE

**When used with AxSOS 3 Titanium Distal Femur Plates, only use the cable plug in the universal holes in the shaft of the plate.**

**Hole number 17 in long AxSOS 3 Distal Lateral Femur Plates is designed slightly in an oblique way to avoid conflicting protection sleeves with the targeting instrumentation. Despite the slightly oblique orientation of hole number 17 one can place a cable plug.**

**When used with the broad or narrow AxSOS 3 Titanium Waisted Compression Plates, only use the cable plug in the universal holes and not oblong compression holes of the plates.**

**Do not mix stainless steel cables or wires with AxSOS 3 Titanium plates. Only use cobalt chrome wires or cables. Tests have been performed with the Vitallium (cobalt chrome) cables of the Dall–Miles Cable System from Stryker.**

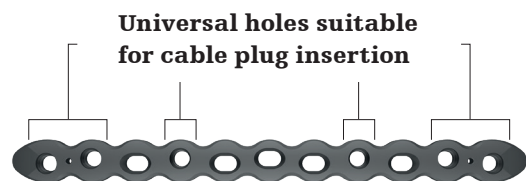
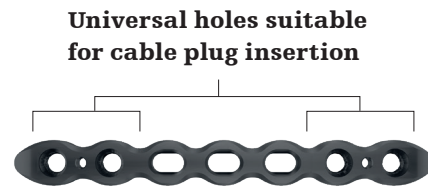
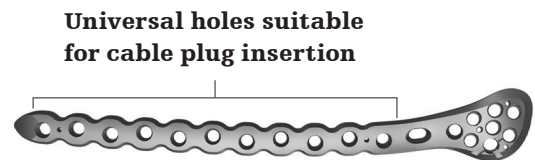
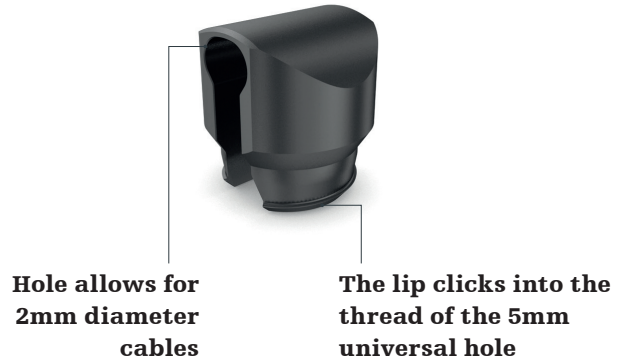



## 5.0mm Cable Plug

### Cable Plug insertion and cable application

Insert an AxSOS 3 Titanium Cable Plug by clicking it into the appropriate universal hole (fig. 40). At least one “click” shall be emitted to allow for engagement of the Cable Plug and the threads of the universal hole. Alternatively the AxSOS 3 Titanium Cable Plug can be screwed in by turning at least half a turn clockwise.

Insert a cable through the eyelet of the Cable Plug. In case one uses a beaded cable, slide the sleeve onto the cable before sliding through the Cable Plug (fig. 41).

Proceed as described in the respective instructions for use of the cabling system.

Then, tighten the cable and crimp the sleeve which usually sits aside the plate. As a last step, cut the cable near the crimped sleeve (fig. 42).

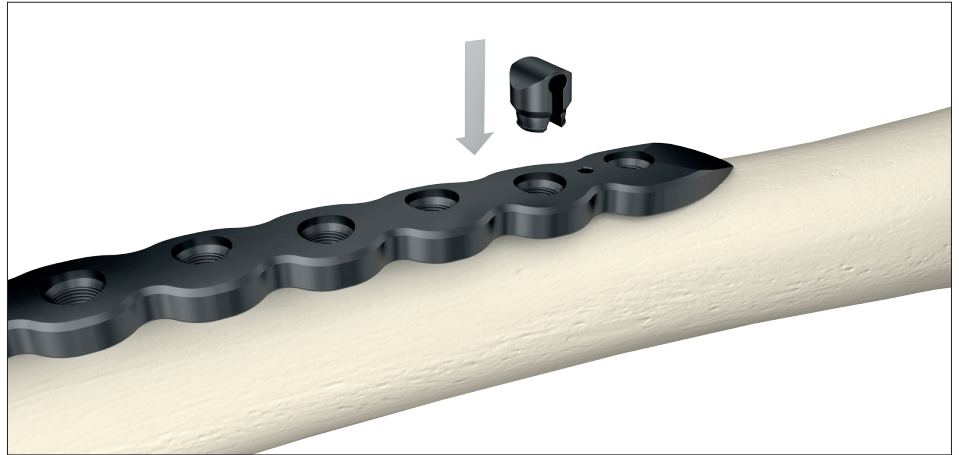

Fig. 40

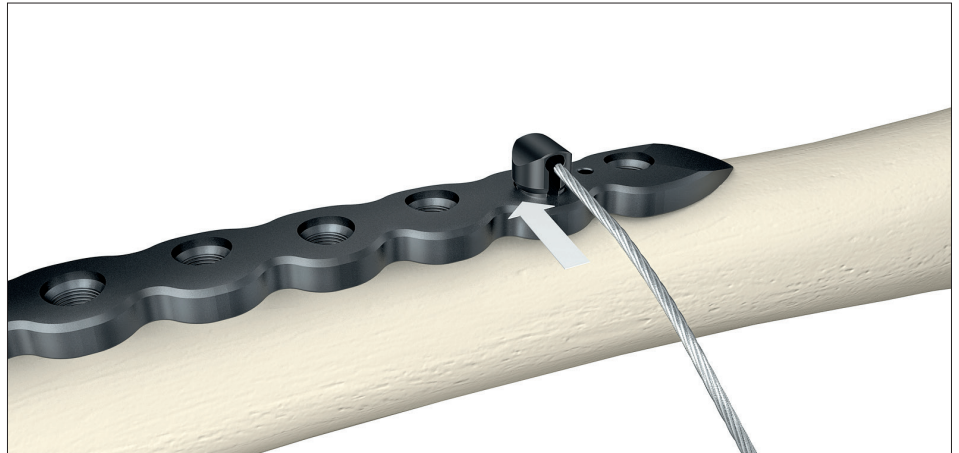

Fig. 41

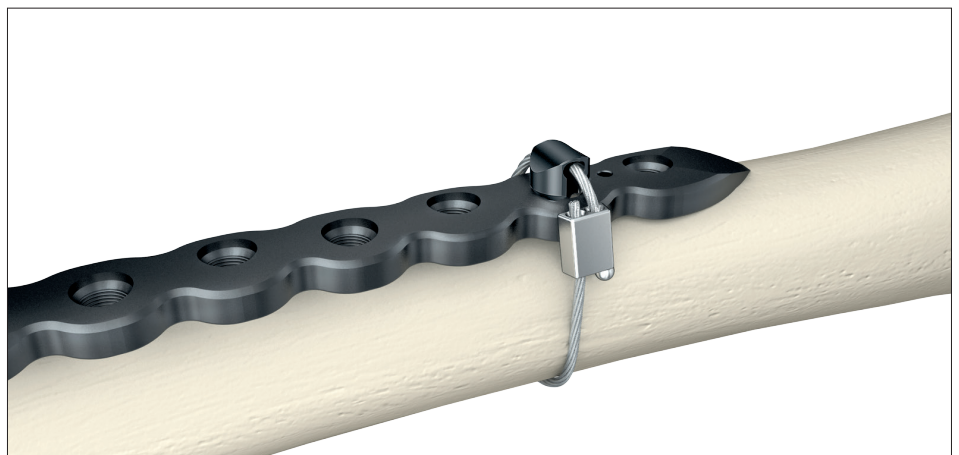

Fig. 42

# 5.0mm Cable Plug

## Cable Plug removal

If a Cable Plug has to be removed simply cut or remove the cable and then unscrew the cable plug counterclockwise (fig. 43). The Cable Plug can be re-seated up to 3 times intraoperatively. As any implant, cable plugs are for single patient use only.

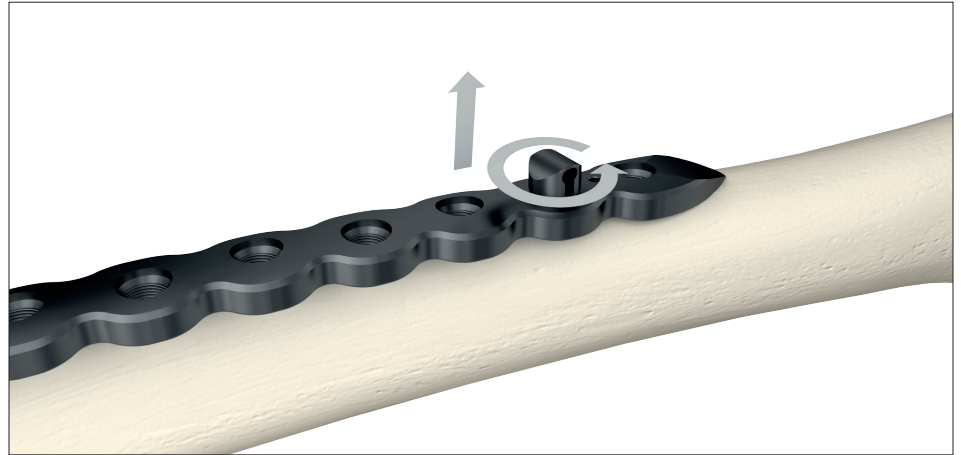
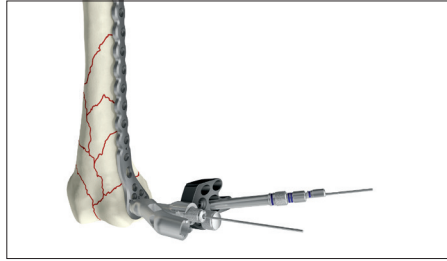

Fig. 43

## Additional tips

### ⚠ CAUTION

1. **Always use the threaded drill sleeve** when drilling for locking screws.



Freehand drilling can lead to a misalignment of the screw and therefore may result in screw jamming during final insertion. It is essential to drill the core hole in the correct trajectory to facilitate accurate insertion of the locking screws.

2. **It is recommended that screw insertion be performed using the soft tissue protection sleeve to ensure proper screw alignment in the core hole.**

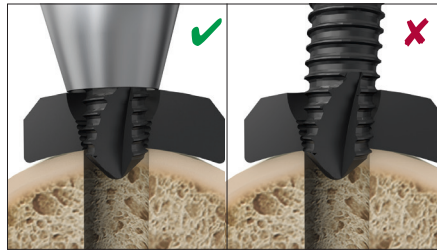

Freehand screw placement may result to a misalignment of the threads in the screw/plate interface during final insertion resulting in screw jamming.

### ⚠ CAUTION

3. If power insertion is selected use low speed only, **do not apply axial pressure**, and never push the screw through the plate! Stop power insertion approximately 1cm before engaging the screw head in the plate.

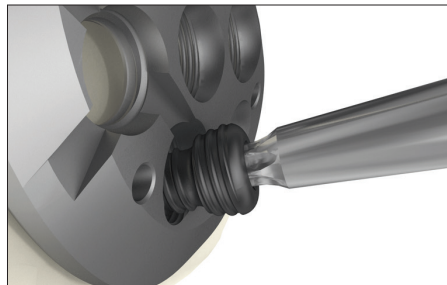

Power can negatively affect final screw insertion, and if used improperly, can damage the screw/plate interface (screw jamming). This can lead to screw head breaking or stripping or may result in damaging or breakage of the screw driver blade.

4. It is advisable to **tap hard** (dense) **cortical bone** before inserting a locking screw.

Use Ø5.0mm tap (ref 703554).

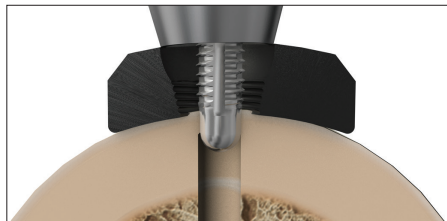

The spherical tip of the tap is designed to precisely align with the instrument in the pre-drilled core hole during thread cutting. This will facilitate subsequent screw placement.

### ⚠ CAUTION

5. **Do not use power for final insertion of locking screws.** It is imperative to engage the screw head into the plate using the torque limiter. Ensure that the screwdriver tip is fully seated in the screw head, but do not apply axial force during final tightening. If the screw stops short of final position, back up a few turns and advance the screw again (with torque limiter on).



# SPS Titanium – AxSOS 3 Titanium compatibility chart

The chart shows the compatibility of SPS Small and Basic Fragment Titanium screws with AxSOS 3 Titanium Plates and vice-versa.

			Screws																									
			AxSOS 3 Ti 4.0mm					AxSOS 3 Ti 5.0mm								SPS 3.5mm		SPS 4.5mm		SPS 2.7mm								
			661014/-095	661410/-520	607310/-400	607410/-500	661612/-640	661004	661114/-195	661714/-850	608230/-350	608020/-150	608445/-550	661922/-975	661308/-320	661005	991088S	661002S	603010/-090	604010/-060	604210/-260	601014/-150	602030/-150	602245/-400	602420/-550	605008/-060		
			4.0mm locking Ti screw	3.5mm cortex Ti screw	4.0mm cancellous Ti screw - full thread	4.0mm cancellous Ti screw - partial thread	3.5mm cortex shaft Ti screw	4.0mm blind screw	5.0mm locking screw	4.5mm cortex Ti screw	6.0mm cancellous Ti screw - TL-16	6.0mm cancellous Ti screw - full thread	6.0mm cancellous Ti screw - TL-32	4.5mm cortex shaft Ti screw	5.0mm periprosthetic locking screw	5.0mm blind screw	5.0mm variable angle extension arm*	5.0mm cable plug	SPS 3.5mm Ti cortical screw	SPS 4.0mm Ti cancellous full	SPS 4.0mm Ti cancellous partial	SPS 4.5mm Ti cortical screw	SPS 6.5mm Ti cancellous 16.0mm	SPS 6.5mm Ti cancellous 32.0mm	SPS 6.5mm Ti cancellous full thread	SPS 2.7mm Ti cortical screw		
Plates	AxSOS 3 Ti 4mm	627302/-352	Proximal lateral tibia plate	X	X	X	X	X	X										X	X	X							
		627404/-452	Distal medial tibia plate	X	X	X	X	X	X											X	X	X						
		627454/-500	Distal anterolateral tibia plate	X	X	X	X	X	X											X	X	X						X
		627704/-752	Proximal medial tibia plate	X	X	X	X	X	X											X	X	X						
		627203/-250	Proximal lateral humerus plate	X	X	X	X	X	X											X	X	X						
		627502/-520	4mm compression plate	X	X	X	X	X	X											X	X	X						
	AxSOS 3 Ti 5mm	627604/-650	Distal lateral femur plate							X	X	X	X	X	X	X	X	X	X				X					
		627532/-552	5mm compression plate narrow							X	X	X	X	X	X	X	X	X	X				X					
		627566/-582	5mm compression plate broad							X	X	X	X	X	X	X	X	X	X				X					
	SPS Small Fragment	621423/-436	T-plate		X	X	X	X												X	X	X						
		621463/-468	Oblique T-plate		X	X	X	X												X	X	X						
		621443/-450	Cloverleaf plate		X	X	X	X												X	X	X						
		621122/-134	One third tubular plate		X	X	X	X												X	X	X						
	SPS Basic Fragment	620413/-413	T-plate																				X	X	X	X		
		620454/-458	T-buttress plate																				X	X	X	X		
		620704/-706	L-buttress plate, left																				X	X	X	X		
		620754/-758	L-buttress plate, right																				X	X	X	X		

\* This product is not CE marked in accordance with applicable EU regulations and directives. Stryker is not marketing or distributing this product in the EU. Any reference to this product is for presentation purposes only.

# Notes

# Notes

# Notes

This document is intended solely for the use of healthcare professionals. A surgeon must always rely on his or her own professional clinical judgment when deciding whether to use a particular product when treating a particular patient. Stryker does not dispense medical advice and recommends that surgeons be trained in the use of any particular product before using it in surgery.

The information presented is intended to demonstrate a Stryker product. A surgeon must always refer to the package insert, product label and/or instructions for use, including the instructions for cleaning and sterilization (if applicable), before using any Stryker product. Products may not be available in all markets because product availability is subject to the regulatory and/or medical practices in individual markets. Please contact your Stryker representative if you have questions about the availability of Stryker products in your area.

Stryker Corporation or its affiliates own, use, or have applied for the following trademarks or service marks: AxSOS 3, Stryker. All other trademarks are trademarks of their respective owners or holders.

If not indicated specifically in this operative technique the products listed above are CE marked.

Content ID: AxSOS-ST-46 Rev 6, 10-2019

Copyright © 2019 Stryker



CE 0123

**Manufacturer:**

Stryker GmbH  
Bohnackerweg 1  
2545 Selzach  
Switzerland  
stryker.com