



VALOR™

Hindfoot Fusion System



SURGICAL TECHNIQUE

VALOR™
Hindfoot Fusion System

SURGICAL TECHNIQUE

Contents

Chapter 1	4	Introduction
	4	Indications
	4	Contraindications
Chapter 2	5	Design Rationale
	5	System Implants
	9	System Instrumentation
Chapter 3	10	Surgical Technique
	10	Surgical Technique Overview
	11	Positioning & Preparation
	12	Entry Point Incision & Wire Insertion
	13	Reaming
	15	Targeting Guide Assembly
	19	Nail Insertion
	24	Compression Screw Placement & Internal Compression
	27	Ensuring Clearance of the Calcaneal Screw
	28	Calcaneal Screw Placement
	30	Subtalar Screw Placement
Chapter 4	34	Ordering Information
	34	Implants
	35	Instruments
	35	Templates
Chapter 5	36	Instrumentation and Consumables

Proper surgical procedures and techniques are the responsibility of the medical professional. The following guidelines are furnished for information purposes only. Each surgeon must evaluate the appropriateness of the procedures based on his or her personal medical training and experience. Prior to use of the system, the surgeon should refer to the product package insert for complete warnings, precautions, indications, contraindications and adverse effects. Package inserts are also available by contacting the manufacturer. Contact information can be found on the back of this surgical technique and the package insert is available on the website listed.

Please contact your local Wright representative for product availability.

Introduction



Designed by foot and ankle surgeons specifically for the unique challenges of hindfoot arthrodesis, the VALOR™ Hindfoot Fusion System represents the latest and most comprehensive system for achieving arthrodesis of the ankle and hindfoot. By combining streamlined and reliable instrumentation with an array of anatomically-aligned screw trajectories and an internal compression mechanism, the VALOR™ Hindfoot Fusion System seeks to simplify the arthrodesis procedure while providing the optimal conditions for a successful fusion.

INDICATIONS

The VALOR™ Ankle Fusion Nail System is intended to facilitate tibiotalar arthrodesis to treat severe foot/ankle deformity, arthritis, instability, and skeletal defects after tumor resection. These include Neuro-osteoarthropathy (Charcot's Foot), Avascular Necrosis of the talus, failed joint replacement, failed ankle fusion, distal tibia fracture non-unions, Osteoarthritis, Rheumatoid Arthritis, and Pseudoarthrosis.

CONTRAINDICATIONS

Patients should be warned of these contraindications:

- » Infection
- » Physiologically or psychologically inadequate patient
- » Inadequate skin, bone, or neurovascular status
- » Irreparable tendon system
- » Possibility for conservative treatment
- » Growing patients with open epiphyses
- » Patients with high levels of activity

Prior to use of the system, the surgeon should refer to the product package insert for complete warnings, precautions, indications, contraindications and adverse effects. Package inserts are also available by contacting the manufacturer. Contact information can be found on the back of this surgical technique and the package insert is available on the website listed.

Design Rationale

SYSTEM IMPLANTS

The implants of the VALOR™ Hindfoot Fusion System combine the benefits of multiplanar anatomical screw trajectories with an internal compression mechanism to provide a comprehensive solution to fusion procedures of the tibiotalocalcaneal joints.

The VALOR™ Hindfoot Fusion Nail

The centerpiece of the system is the VALOR™ Hindfoot Fusion Nail, which, in conjunction with 5.0mm Screws, provide the stability and rigidity demanded in hindfoot arthrodesis procedures.

- » Available in two primary diameters – 10.0mm and 11.5mm – the VALOR™ Nail is designed to withstand the bending stresses that occur in the ankle. | **FIGURE A**
- » With lengths from 150mm to 300mm, the VALOR™ Nail provides the surgeon the ability to treat patients of varying anatomies and deformities. | **FIGURE A**
- » By accommodating the unique anatomy of the right and left hindfoot with multiplanar screw trajectories, the VALOR™ Nail is provided in a Right and Left orientation, color-coded in Silver and Gold, respectively. | **FIGURE A.**



FIGURE A

*A sampling of the various sizing arrangements of VALOR™ Nail.
(Note the consistent positioning of the primary Proximal Tibial Screws.)*

VALOR™ 5.0mm Screws

In order to target the highest quality bone in the hindfoot and tibia, the VALOR™ Nail has multiple screw positions, which combine to allow optimal bone fixation and maximum construct stability. | **FIGURE B**

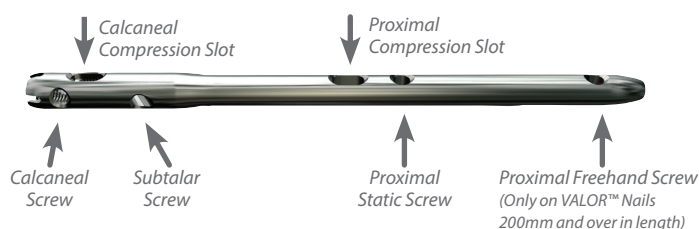

FIGURE B
VALOR™ Nail Screw positions.

Aligned along the sagittal plane, the Proximal Screws combine to allow strength and stability in the tibia by allowing screw fixation closer to the ankle joint.

- » As noted in **FIGURE A**, the primary Proximal Tibial Screws are consistently located on all Nail lengths closer to the ankle joint in metaphyseal bone.
 - This positioning provides added joint stability and minimizes the bending stresses transferred through the Nail by an unstable ankle joint prior to fusion.
 - Additionally, by reducing the arm length of the Targeting Guide, the Proximal Screws can be more accurately and reliably targeted.
- » Two primary Proximal Screws are offered – a Static and Dynamic version – to allow the surgeon to control the axial translation of the Nail in the tibia.

| **FIGURE B**

- The Proximal Static Screw mitigates both axial and rotational motion within the tibia, ensuring consistent stability throughout the fusion process.
- The Proximal Dynamic Screw is positioned in the Proximal Compression Slot of the VALOR™ Nail, and, when used in isolation, provides the opportunity for dynamization postoperatively in cases of delayed union.
- » Additionally, on VALOR™ Nails 200mm and longer, the Proximal Freehand Screw is placed at the proximal tip of the Nail, to provide additional stability.

The multiplanar anatomical screw trajectories of the VALOR™ Nail provide for optimal bone fixation and implant stability by accounting for the unique anatomy of the hindfoot.

- » Aligned 7-degrees off the anterior-posterior axis and 10-degrees distal-to-proximal, the distal Calcaneal Screw is oriented to achieve maximum bone purchase in the body of the calcaneus. | **FIGURES C & D**
- » The Calcaneal Compression Screw's lateral-to-medial insertion orientation avoids critical neurovascular anatomy on the medial side.
- » The Subtalar Screw provides stability to the talo-calcaneal joint by fixing the talar and calcaneal bodies through the VALOR™ Nail.
- » Oriented 57-degrees proximally off the transverse plane and 20-degrees off the trajectory of the Calcaneal Screw, the Subtalar Screw ensures the optimal alignment within the calcaneus and talus to ensure stable fixation. | **FIGURE C & D**

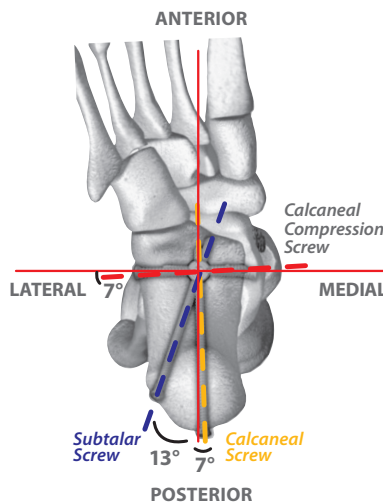

FIGURE C
Plantar view of the VALOR™ Screw trajectories. Note the 7-degree off-axis alignment of the Calcaneal Screw and the 20-degree differential between the Calcaneal and Subtalar Screws, which combine to provide optimal bone fixation into the hindfoot.

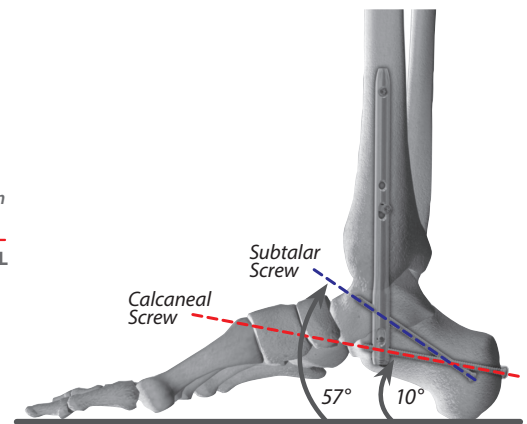

FIGURE D
The Screw trajectories of the Subtalar and Calcaneal Screws.



FIGURE E
The VALOR™ Screw

The VALOR™ Screw System

The 5.0mm VALOR™ Screws are designed to allow rigid fixation of the Nail in the extreme conditions of ankle arthrodesis. Their strength is provided by the solid-core titanium alloy design, and enhances stability by providing for proximal cortical engagement. | **FIGURE E**

Aside from protecting the distal end of the VALOR™ Nail, the VALOR™ End Cap also has the ability to lock the Calcaneal Screw. When combined with the locking abilities of the Internal Compression Screw, the system provides dual locking of both Calcaneal Screws, minimizing the risk of screw back-out.

The VALOR™ Internal Compression Mechanism

Achieving and maintaining compression at the arthrodesis site is critical, especially for the unstable ankle and subtalar joints. The VALOR™ Hindfoot Fusion System provides two methods for intra- and postoperative compression – an Internal Compression Mechanism and a Dynamization Screw:

- » The initial placement of a Proximal Dynamic Screw provides dynamic compression that continues postoperatively.
- » The system's primary means of compression is the Internal Compression Mechanism, which can achieve up to 5mm of compression intraoperatively.
 - Advancing the pre-loaded internal compression mechanism translates the lateral-to-medial Calcaneal Screw to the top of the Compression Slot, thereby achieving compression of both the subtalar and ankle joints, as well as locking the Compression Screw into position. | **FIGURE F**

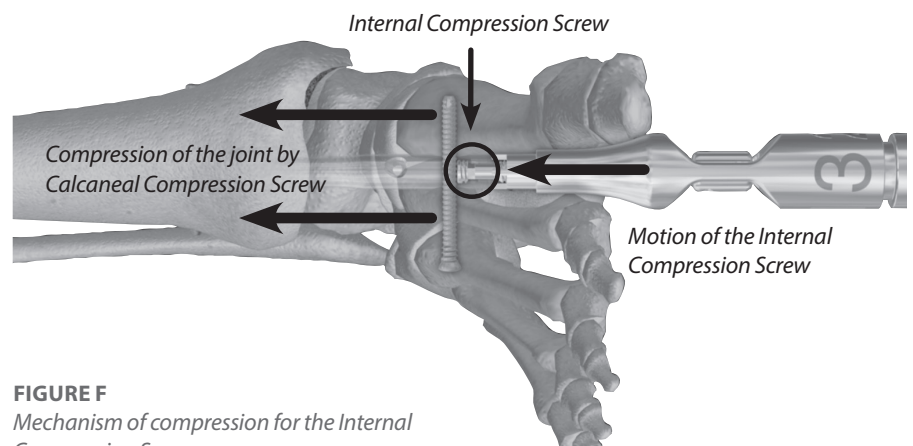

FIGURE F
Mechanism of compression for the Internal Compression Screw.

SYSTEM INSTRUMENTATION

The instrumentation in the VALOR™ Hindfoot Fusion System was specifically designed by foot and ankle surgeons for simplicity and reliability in even the most challenging cases. The instrumentation is highlighted by the Targeting Guide, which has a streamlined and radiolucent design that allows clarity and accuracy. Additionally, when combined with the QwikTrigger Positioning System, the system assists in guidance and positioning throughout the entire procedure. | **FIGURE G**

The QwikTrigger Positioning System

The VALOR™ Instrument System features the QwikTrigger Positioning System, which enables quick and efficient reorientation of the Targeting Guide for the multiplanar screw orientations, without losing reliability and accuracy.

The foundation of the system is the QwikTrigger at the base of the Targeting Guide which, when activated, disengages the locking mechanism between the Connector and the Targeting Guide, thereby allowing rotational repositioning of the Guide.

Additionally, the System features the “1-2-3” Orientation Markings, as denoted by the large numbers printed at the base of the Connector. These numbers, when aligned with the arrow at the base of the Targeting Guide, directs the user through the procedure in a step-by-step manner, facilitating proper alignment and targeting of all multiplanar screws.

FIGURE G

The VALOR™ Targeting Guide Assembly with the QwikTrigger Positioning System (RED) and the “1-2-3” Orientation Markings (BLACK).



Surgical Technique

SURGICAL TECHNIQUE OVERVIEW

The VALOR™ Hindfoot Fusion System was designed for clarity and simplicity of the hindfoot arthrodesis procedure. In order to provide a complete explanation of the procedure using the VALOR™ implants and instrumentation, a detailed surgical technique is described on the following pages, with a comprehensive listing of tips. However, for easy reference, a general overview of the key steps is outlined below:

- » Prepare Joints and Medialize Ankle
- » Insert Entry Guidewire
- » Entry Ream through hindfoot and into tibia
- » Replace Guidewire with Beaded-Tip Wire
- » Flexible Ream to 0.5-1.0mm over diameter of Nail
- » Attach Nail to Targeting Guide
 - Ensure proper positioning of Internal Compression Screw
- » Insert Targeting Guide Assembly on medial side of foot
 - Verify Position 1 alignment
 - Remove Guidewire

- » General Screw Technique
 - Insert Guide Tube into Targeting Guide
 - *Dynamic Tube for Compression Slots*
 - Insert and Secure Drill Tube
 - Insert and Impact Trocar
 - *Remove Trocar*
 - Drill and Measure Screw Length
 - *Remove Drill and Drill Tube*
 - Insert Screw with STAR 25 Driver
 - *Remove Driver and Guide Tube*

- » Place Proximal Tibial Screw(s) – Dynamic and/or Static
 - Dynamic Guide Tube aligned at top of slot
- » Rotate Laterally to Position 2
- » Place Calcaneal Compression Screw
 - Dynamic Guide Tube aligned at bottom of slot
- » Advance Internal Compression Screw with 4.0mm Hex Driver
 - Ensure clearance of Calcaneal Screw hole fluoroscopically
- » Rotate Posteriorly to Position 3
- » Place Calcaneal Screw
- » Place Subtalar Screw with Outrigger Guide
- » Detach Targeting Guide from Nail
- » OPTIONAL: Insert Proximal Freehand Screw
- » OPTIONAL: Insert End-Cap

TIPS

C-ARM POSITIONING

- » C-ARM is positioned perpendicular to the leg.
- » Verify attainment of both mediolateral (ML) and anteroposterior (AP) views.
- » Check that multiple fluoroscopic views can be easily attained, as they can be used to verify the successful targeting of the screws.

PREOPERATIVE TEMPLATING

Preoperative evaluation of implant sizing and positioning can be accomplished with the x-ray templates, available through Wright in a transparency or digital form.

POSITIONING & PREPARATION

Patient Positioning

Appropriate positioning of the patient on the table can assist in achieving proper alignment of the fusion site. A variety of positions are acceptable (supine, lateral, or prone). **FIGURE 1** Although, the supine position is generally recommended, as it provides better rotation and manipulation of the ankle and hindfoot. In the supine position, an ipsilateral bump can be placed to position the extremity in a more neutral position.

Neutral alignment of the knee and ankle should be confirmed initially and continually assessed intraoperatively, especially during the Guidewire insertion and reaming procedures.

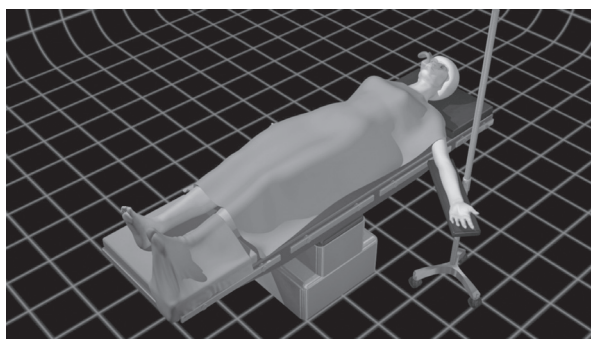

FIGURE 1
Supine positioning of the patient.

Joint Preparation

Pre-existing deformities are corrected prior to the preparation and insertion of the VALOR™ Nail. Factors such as the anatomy of the deformity, surgeon preference, and patient positioning may determine the appropriate approach chosen for joint preparation and alignment.

Ankle Positioning

Upon properly aligning and preparing all the joint surfaces, the ankle is positioned for arthrodesis. Medialization of the ankle with thorough debridement of medial gutter facilitates positioning in the center of the calcaneus, talus and tibia.

The ankle is placed in neutral dorsiflexion and symmetric external rotation of the contralateral ankle. Maintenance of this positioning is essential throughout the procedure, and may be facilitated by provisionally placing a wire on the periphery of the ankle joint.

TIPS

BEADED VS. ENTRY GUIDEWIRES

- » The Trocar-tipped Entry Guidewire creates the initial path through the bones of the hindfoot and into the tibia for the Reamers – and, ultimately, the VALOR™ Nail. It is over this Entry Guidewire that the cannulated Entry Reamer prepares the distal canal.
- » The Beaded-Tip Guidewire permits guidance of the Flexible Reamers into the Tibia. The Guidewires have a beaded-tip to allow the extraction of the Flexible Reamer Head if it were to become detached from the Flexible Reamer Shaft.
- » The 32" length of the Beaded Guidewire allows for the insertion of the Nail and Targeting Guide Assembly over the Guidewire.



3.0mm Entry Guidewire
(4150004025)

ENTRY POINT INCISION & WIRE INSERTION

Entry Point Incision

A 2-3cm longitudinal incision is made on the plantar aspect of the heel, anterior to the subcalcaneal fat pad and slightly lateral to the midline. **FIGURE 2** The incision is continued down to the surface of the calcaneus by bluntly dissecting through the plantar soft tissues, noting the location of neurovascular bundles.



FIGURE 2
Entry point incision on the plantar surface.

Guidewire Insertion

Ensuring proper alignment of the hindfoot is maintained, the 3.0mm Entry Guidewire (4150004025) is inserted through the calcaneus, talus and into the tibia. **FIGURE 3** Multiple fluoroscopic views of both AP and ML positions are attained throughout the process to ensure that the Guidewire proceeds down the center of the calcaneus, talus and tibial medullary canal. **FIGURE 4** The Entry Guidewire is advanced until it is a few centimeters beyond the desired length of the VALOR™ Nail.

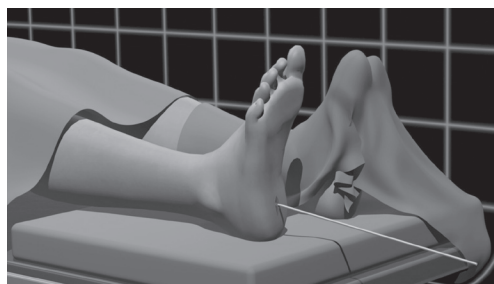

FIGURE 3
Insertion of the Entry Guidewire.

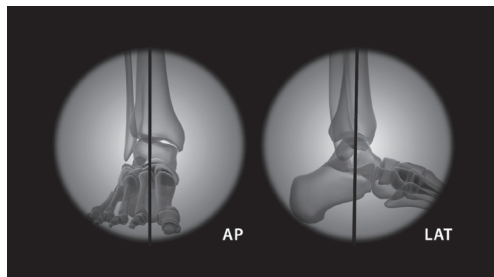

FIGURE 4
Fluoroscopic alignment of Entry Guidewire.

TIPS

ENTRY REAMER VS. FLEXIBLE REAMING

- » The Entry Reamer creates the Nail's distal diameter through the bones of the hindfoot and into the distal tibia.
- » The 12.0mm diameter of this distal segment is larger than the proximal diameter of the Nail in the tibia – at 10.0 or 11.5mm – to account for the internal compression mechanism, as well as to provide more structural strength in the hindfoot.
- » The reamed diameter of this distal segment is approximately line-to-line with the Nail's 12.0mm distal diameter. This creates a press-fitting of the Nail into the bones of the hindfoot, assisting in manual compression of the fusion joints during insertion of the Nail.
- » The Reamer tapers down to a diameter of 9.0mm at the proximal tip to initiate the canal of the distal tibia. For this reason, it is recommended to start with a 9.0mm Flexible Reamer Head.

FLEXIBLE REAMER

- » The Flexible Reamer creates the Nail's proximal diameter in the tibia's medullary canal.
- » The flexible nature of the reaming shaft permits navigation along the length of the tibia, as well as minimizing intramedullary pressures that may arise during the reaming process.



Tissue Protector
(4150011013)

Entry Reamer
(4150002090)



3.0mm Beaded-Tip Guidewire
(4150004030)

REAMING

Entry Reaming

The Tissue Protector (4150011013) and Entry Reamer (4150002090) are placed over the Entry Guidewire (4150004030), and the Tissue Protector is set against the plantar surface of the calcaneus. **FIGURE 5** Advance the Entry Reamer through the calcaneus, talus and into the tibia, until the banded line on the Entry Reamer shaft aligns with the end of the Tissue Protector. **FIGURE 6** This position should correspond to an alignment of the distal end of the Reamer's flutes with the plantar border of the calcaneus, as seen under fluoroscopy. **FIGURE 7**

Remove the Entry Reamer and the Entry Guidewire, and replace with the Beaded Guidewire.

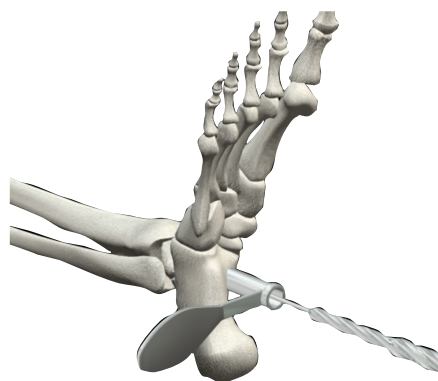

FIGURE 5
Preparation of the Tissue Protector and Entry Reamer.

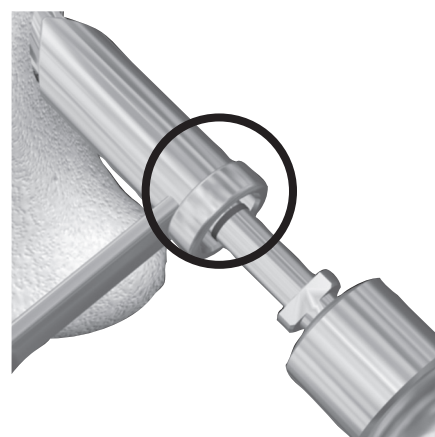

FIGURE 6
Banded marking on Reamer Shaft signifying approximate final positioning of insertion.



FIGURE 7
Fluoroscopic verification of Entry Reamer positioning.

TIPS

FLEXIBLE REAMING

CHATTER OF REAMER

- » Aside from a fluoroscopic assessment, evaluation of reaming diameter can be determined based on the 'chatter' of the reamer.
- » Some 'chatter' is desired as it signifies fit-and-fill of the diaphyseal canal.

OVER-REAMING DIAMETER

- » It is suggested to ream between 0.5 and 1.0mm over the diameter of the Nail.
- » This range balances easy-insertion of the Nail into the reamed canal and the minimization of translational rotational movement of the Nail prior to fixation of the Nail with Screws.
- » Over-reaming by 0.5mm minimizes movement during initial insertion by creating a relative press-fit into the medullary canal. However, due to the snugness of the Nail within the canal, it can lead to fracturing of the tibia during insertion in poor quality bone.
- » A 1.0mm over-ream diameter avoids complications during insertion, but can permit translational and rotational movement of the Nail intraoperatively during screw insertion.
- » The exact reaming diameter is left to the discretion of the surgeon.

ALIGNMENT DURING REAMING

- » To achieve optimal alignment of the ankle joint and hindfoot, ensure that the ankle is held in proper alignment during the entire reaming and insertion process.
- » The surgeon may consider inserting an additional larger-diameter wire (like a Steinmann pin) across the ankle joint to assist in the maintenance of proper alignment.

Flexible Reaming

Attach the 9.0mm Flexible Reamer Head (4150006090-6125) with self-retaining feature onto the Flexible Reamer Shaft 4150016000). Slide the Flexible Reaming assembly with the Tissue Protector onto the Beaded Guidewire. Flexible ream into the medullary canal of the tibia until the desired depth is reached as confirmed by fluoroscopy.

FIGURE 8 Additionally, the Flexible Reamer Shaft has depth markings, signified by periodic bands on the shaft, that, when aligned with the end of the Tissue Protector, correspond to the lengths of the VALOR™ Nail. **FIGURE 9** The four bands correspond to available lengths of the Nail - 150mm, 200mm, 250mm, and 300mm. To ensure accurate measurement, the Tissue Protector must be firmly placed against the plantar surface of calcaneus.

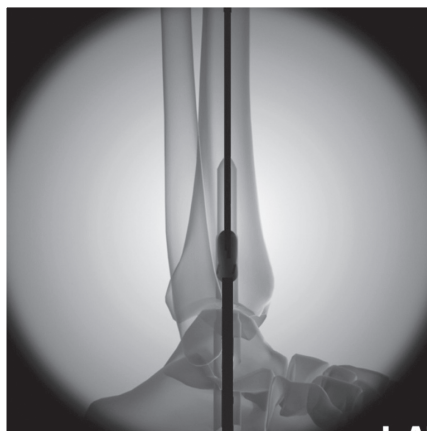

FIGURE 8
Lateral fluoroscopic view of the Flexible Reamer's progression and alignment in the tibial canal.

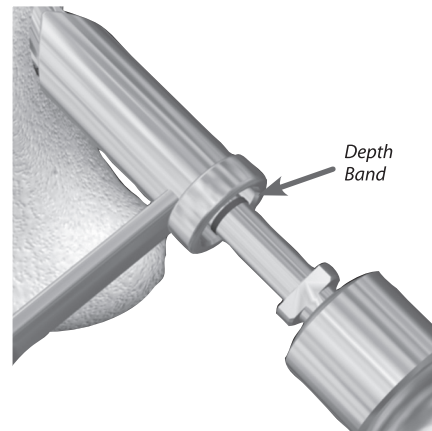

FIGURE 9
Alignment of 3rd band on the Flexible Reamer Shaft and the end of the Tissue Protector signifying approximate depth of a 250mm VALOR™ Nail.

Eight Flexible Reamer Heads are available in 0.5mm diameter increments from 9.0mm to 12.5mm. It is recommended to begin with the smallest diameter head – 9.0mm – and progressively ream in 0.5mm increments until the Flexible Reamer Head diameter is 0.5 to 1.0mm larger than the desired Nail diameter. For example, a 10.0mm diameter Nail would require flexible reaming until the 10.5mm or the 11.0mm Flexible Reamer Head diameter is achieved.



Flexible Reamer Head
(4150006090-6125)



Flexible Reamer Shaft
(4150016000)

TIPS

PRE-LOADED COMPRESSION SCREW

IMPORTANT

- » Failure to verify positioning of the Internal Compression Screw can result in several adverse outcomes of the system:
 - » Obstruction of the compression slot when the screw is too high, resulting in an inability to properly achieve internal compression.
 - » Obstruction of the Calcaneal Screw hole when the screw is too low, resulting in an inability to attach the Targeting Guide Connector to the Nail. Additionally, it could create a loose fit between the Nail and the Connector, culminating in missed screws.



Targeting Guide Assembly

VALOR™ Hindfoot Fusion Nails are offered in two orientations – Left and Right – four lengths - 150mm, 200mm, 250mm and 300mm - and two proximal length diameters – 10.0mm and 11.5mm. The 12.0mm distal segment diameter is uniform for all sizes of Nails.

The Left and Right orientation of the VALOR™ Nails accounts for the unique screw trajectories of the hindfoot. For example, the Calcaneal Screw is aligned 7° lateral to the sagittal plane to properly track the slight lateral drift of the calcaneal neck. In order to target these variable screw trajectories, the Left and Right VALOR™ Nails have a corresponding Left and Right Connector (4150011003-4), which are color-coded according to their orientation – the Left Nail and the Left Connector are both colored gold, while the Right Nail and Connector are silver. **FIGURE 10**

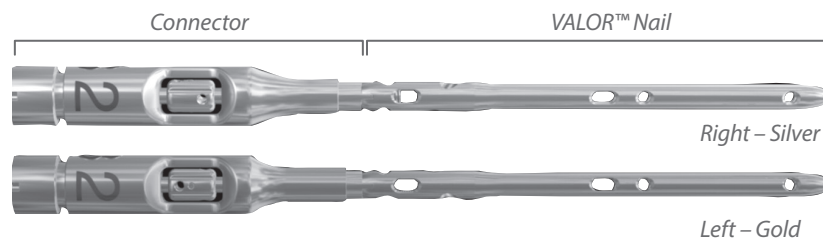

FIGURE 10
Color-coding of the VALOR™ Nails and the Targeting Guide Connectors.

Prior to assembling the Nail onto the Targeting Guide, verify the positioning of the pre-loaded Internal Compression Screw within the distal end of the Nail. First, remove the silicone plugs (if applicable) from the compression slot and the end of the Nail. Then, examine the location of the Internal Compression Screw within the Nail. The proper position of the Internal Compression Screw is when the top of the screw is just flush with the bottom (distal) end of the oblong compression slot. **FIGURE 11** The 4.0mm Hex Driver (4150003040) can be used to advance or retract the internal screw until the appropriate position is achieved.

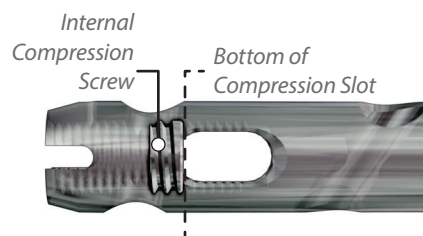

FIGURE 11
Proper positioning of the Internal Compression Screw verified prior to implantation.

If compression is not desired or if the surgeon is satisfied with the apposition of the ankle joint after debridement, remove the Internal Compression Screw with the 4.0mm Hex Driver prior to attachment to the Targeting Guide Connector. Alternatively, the screw can be removed intraoperatively by detaching the Targeting Guide Connector and using the Hex Driver to remove the Screw.

TIPS

ATTACHING THE NAIL TO THE CONNECTOR

- » The Thumb Screw on the Connector must be pushed up to extend the Connector screw into the distal threads of the Nail.
- » The simplest way to ensure connection between the Connector and the Nail is to position the Nail and the Connector upside-down, thereby allowing gravity to drive the Connector's screw into the threads of the Nail.

SECURING NAIL TO THE CONNECTOR

- » **CAUTION:** Do not accept a sloppy or loose fit between the Connector and Nail, as any instability can result in inaccurate targeting of the screws.
- » **CAUTION:** Do not over-tighten the connector to the Nail, as damage may occur to the connection assembly or the tightening bar.



Tightening Bar
(4150001014)

Attach the VALOR™ Nail to the appropriate Left or Right Connector by first aligning the three prongs on the Connector to the three slots at the base of the VALOR™ Nail. **FIGURE 12** Securely seat the Nail onto the Connector by advancing the screw with the Thumb Wheel on the Connector into the distal threads of the Nail. To avoid a loose, inaccurate fit between the Connector and the Nail, advance the Thumb Screw with the Tightening Bar (4150001014). **FIGURE 13**

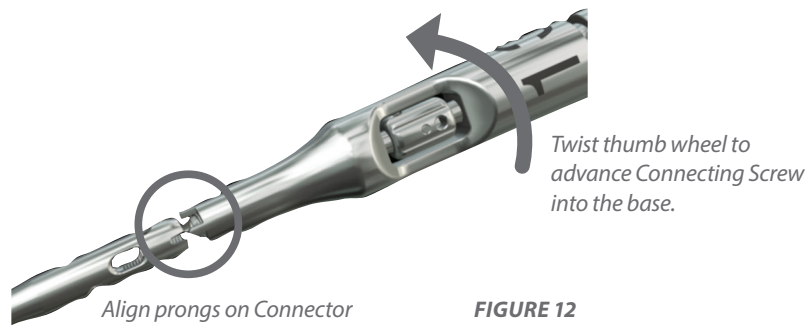

Align prongs on Connector with slots at the bottom of the VALOR™ Nail.

FIGURE 12
Attaching the VALOR™ Nail to the Targeting Guide Connector.

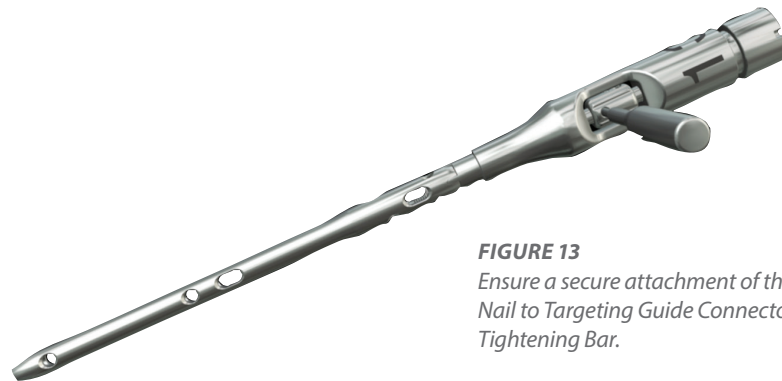

FIGURE 13
Ensure a secure attachment of the VALOR™ Nail to Targeting Guide Connector with Tightening Bar.

TIPS

TARGETING GUIDE ASSEMBLY

- » The main Targeting Guide targets all screws except for the Subtalar and Proximal Freehand Screw.
- » The Targeting Guide Outrigger allows proper targeting of the Subtalar Screw.
- » The Outrigger can only be slid onto the Main Targeting Guide in one orientation due to differential slot sizes on both sides of the Targeting Guide.
- » If difficulty in attaching the Outrigger to the Targeting Guide is encountered, a variety of solutions may resolve the situation:
 - » Flip the Outrigger upside-down to ensure that the angled faces are facing down.
 - » Unscrew the Thumb Screw completely.
- » Because of the tight connection between the Connector and the Targeting Guide, it is easiest to twist the Connector back-and-forth while sliding the Connector onto the Peg.



Assemble the Targeting Guide (4150011000) by attaching the Subtalar Outrigger Guide (4150011002) onto the main Targeting Guide. First, ensure that the Thumb Screw is completely retracted. Then, with the angled faces of the Outrigger facing down, slide the Outrigger onto the Targeting Guide first horizontally and then vertically. **FIGURE 14** Align the top of the guide with the band marked on the Targeting Guide, then engage the Thumb Screw to securely attach the Outrigger to the Targeting Guide.

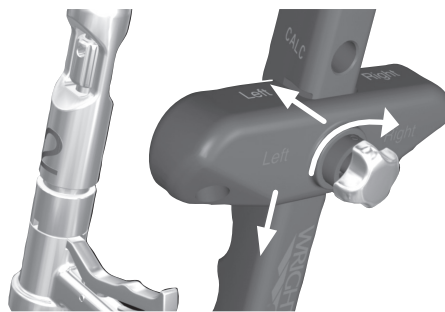

STEP 1 - Slide Outrigger Guide onto the Targeting Guide horizontally in and vertically down.

STEP 2 - Twist Thumb Screw onto the Targeting Guide to secure.

FIGURE 14
Attachment of Outrigger Guide onto Targeting Guide.

Assemble the Targeting Guide to the Connector by sliding the Connector onto the large cylindrical peg at the base of the radiolucent Targeting Guide. Secure Connector onto the Targeting Guide by rotating until the connection locks. The Targeting Guide is then complete. **FIGURE 15**



FIGURE 15
Fully assembled Targeting Guide.

TIPS

THE QWIKTRIGGER POSITIONING SYSTEM

- » The QwikTrigger Positioning System allows quick and efficient targeting of the VALOR™ Nail's multiplanar screw orientations by combining the quick-disengagement abilities of the Trigger mechanism with the "1-2-3" Orientation Procedure.
- » The "1-2-3" numbers printed at the base of the Connector, when aligned with the arrow at the base of the Targeting Guide, can assist the surgeon in remembering related steps for each position:
 - » **POSITION 1 = 1 STEP**
 - » Target Proximal Screw(s)
 - » **POSITION 2 = 2 STEPS**
 - » Target Calcaneal Compression Screw
 - » Advance Internal Compression Screw
 - » **POSITION 3 = 3 STEPS**
 - » Target Calcaneal Screw
 - » Target Subtalar Screw
 - » Target Proximal Freehand Screw (if desired)



The Connectors have large numbers printed at their base that signify the Targeting Guide's relative position when aligned with the arrow on the Targeting Guide's base. These numbers ensure proper alignment and targeting of the multiplanar screws into the VALOR™ Nail, and are followed sequentially by pulling the QwikTrigger at the base of the Targeting Guide and rotating the Guide. The initial position is achieved by rotating the assembly so that the printed number "1" on the Connector aligns with the arrow on the Targeting Guide. **FIGURE 16**



FIGURE 16
Alignment of Position 1.

Verifying Proper Alignment of the Targeting Guide

Before inserting the VALOR™ Nail, verify that the Targeting Guide is properly aligned and will successfully target screw holes. Beginning at the proximal screw holes in Position 1, insert the Static Guide Tube (4150011011) or Dynamic Guide Tube (4150001010) into the corresponding proximal holes on the Targeting Guide. Insert the Drill Tube (4150011012) and Entry Trocar (4150012000) into the Guide Tube, ensuring that the tip of the Trocar is centered into the corresponding hole on the Nail.

Repeat procedure to verify alignment of all screw holes for Positions 2 and 3, and return to Position 1 when complete.

TIPS

- » **CAUTION:** Do not impact the thin metallic arm of the Targeting Guide with the Slap Hammer, as this may cause malalignment of the Targeting Guide and excessive damage to the instrument.
- » The Nail may be inserted over the Guidewire, as the cannulated diameter inside the Nail and Targeting Guide Assembly will accommodate the beaded head of the Guidewire.
- » As a result of the soft cancellous structure of the calcaneus, over-impaction of the Nail during insertion may occur. Correction may be achieved by attaching the Back-Out Plate (4150005000) to the circular groove at the base of the Connector and retro-impacting the plate with the Slap Hammer until proper positioning is achieved.
- » **CAUTION:** Failure to remove the Beaded Guidewire will obstruct the screw holes in the Nail, preventing the drill from passing through the Nail.
- » To prevent gradual drooping of the Targeting Guide arm from proper alignment, an assistant may hold arm in position during the insertion of the Proximal Screws.



Back-Out Plate
(4150005000)



Slap Hammer
(4150005001)

NAIL INSERTION

Rotate the main body of the Targeting Guide to the medial side of the foot. Slide the Targeting Guide Assembly over the Beaded Guidewire and advance into the reamed canal. Final seating is performed by impacting the Slap Hammer (4150005001) against the base of the Targeting Guide Assembly. **FIGURE 17**

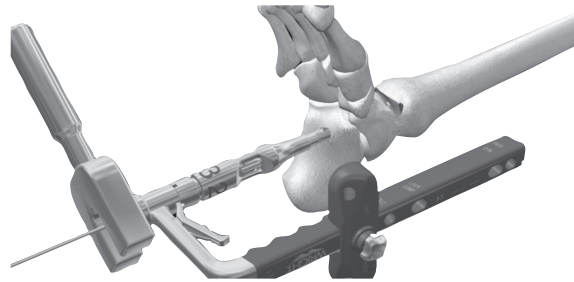

FIGURE 17
Insertion of the Targeting Guide with the Slap Hammer.

Impaction continues under fluoroscopy until final seating is achieved. It is recommended that the bottom of the Nail (as denoted by the single posterior notch at the Nail-Connector interface) is countersunk 5mm past the plantar base surface of the calcaneus to prevent plantar protrusion of the Nail after compression, and the top of the compression slot is just below the subtalar joint line to provide optimal purchase of the Calcaneal Compression Screw before compression. **FIGURE 18** At a minimum, ensure that the distal compression slot is not over the arthrodesis site, if internal compression is desired. Remove the Beaded Guidewire.

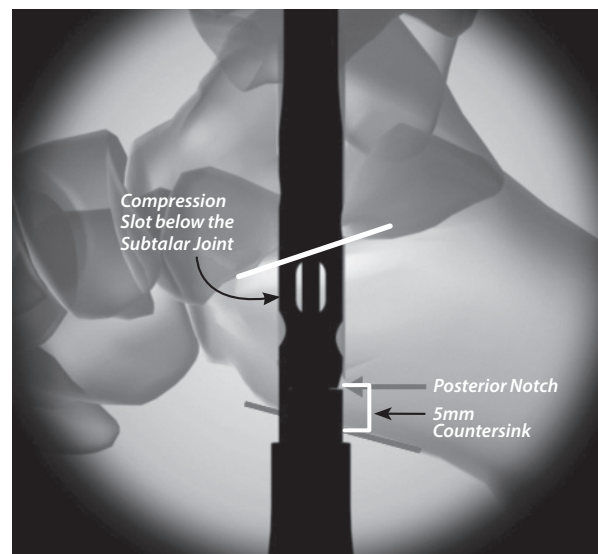

FIGURE 18
Final seating of the VALOR™ Nail as verified under fluoroscopy.

Optimizing Rotational Orientation of the Targeting Guide

To ensure optimal purchase of the multiplanar screw into the hindfoot, the rotational orientation of the Targeting Guide is verified prior to inserting the screws. Verification of rotational alignment is critical to ensure successful placement of the hindfoot screws.

Initial placement in Position 1 should have the Targeting Guide positioned medially and in the coronal plane. After desired Position 1 alignment is achieved, rotate the Targeting Guide to Position 3 to verify the trajectory of the Calcaneal Screw and insertion point of the Subtalar Screw:

- » The Calcaneal Screw trajectory should proceed down the length of the calcaneal body. **FIGURE 19** Verification of this trajectory is accomplished by inserting the Static Guide Tube into the Targeting Guide hole marked “CALC” and visualizing the trajectory line through the calcaneal tuberosity and into the Nail.



FIGURE 19
Verification of Calcaneal Screw trajectory through the calcaneal body.



FIGURE 20
Verification of Subtalar Screw insertion of the lateral aspect of the tuberosity.

- » The Subtalar Screw’s rotational positioning is verified by examining the insertion point of the screw on the lateral aspect of the calcaneal tuberosity. **FIGURE 20** This insertion point should not be on the lateral wall of the calcaneus. Insertion too laterally can cause the drill to skive off the cortical surface, thereby affecting the trajectory of the drill and screw. To verify this insertion point, place the Static Guide Tube into the appropriate hole (Right or Left) on the Outrigger, and examine the position of the tube on the calcaneus.

If the rotational positioning of these screws is not satisfactory, rotate the Targeting Guide assembly accordingly until proper alignment is achieved.

Rotate back to Position 1.

TIPS

DYNAMIZATION AND THE DYNAMIC PROXIMAL COMPRESSION SLOT

- » Dynamization is a strategy for promoting joint fusion. The technique allows a moderate amount of axial motion to create compressive loading of the ankle joint postoperatively.
- » This compressive loading is achieved in the VALOR™ Hindfoot Nail by permitting the Proximal Dynamic Screw (when used in isolation in the tibia) to migrate to the bottom of the slot, thereby allowing axial translation of the Nail into the tibia and compression of the ankle joint.
- » By placing both a Static and Dynamic Proximal Screw into the tibia intraoperatively, the surgeon can delay dynamization until the appropriate time by relying on the Static Screw to prevent axial movement. Once the Static Screw is removed postoperatively, the Dynamic Screw is free to translate axially and dynamization compression is achieved.

ORIENTATION OF THE DYNAMIC GUIDE TUBE

- » For simplicity, the length of the Dynamic Guide Tube should be aligned **away** from the ankle joint.
- » The Proximal Compression Screw is aligned at the **top** of the Proximal Compression Slot.
- » The Calcaneal Compression Screw is aligned at the **bottom** of the Calcaneal Compression Slot.

Proximal Screw Placement

The VALOR™ Hindfoot Fusion Nail has two proximal screw options – a Static Screw and a Dynamic Compression Screw. **FIGURE 21** The Static Screw mitigates axial and rotational motion, while the oblong Compression Slot allows for either static locking or dynamic settling of the Nail (dynamization). Utilization of both screws is recommended to provide optimal rotational stability, and the possibility of postoperative dynamization in the case of delayed fusion. To achieve postoperative dynamization, remove the Proximal Static Screw, which will then permit axial compression during weight-bearing.

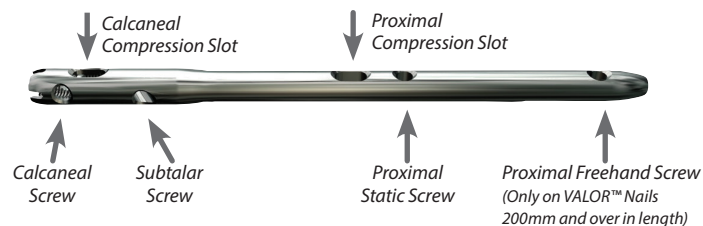

FIGURE 21
VALOR™ Nail Screw positions.

Nail lengths 200mm and longer have a secondary Proximal Freehand Screw hole, through which a screw may be placed with a freehand technique under fluoroscopy guidance as described in the Freehand Screw Section.

If the opportunity for dynamization is desired postoperatively, first place the oblong Dynamic Guide Tube into the oval Proximal Compression Slot – marked “DYN” – on the Targeting Guide. **FIGURE 22A** Align the length of the Dynamic Guide Tube with the top of the Compression Slot. After insertion of the Proximal Dynamic Screw, insert the Static Guide Tube into the round Proximal Static Screw hole on the Targeting Guide – marked “Prox”. **FIGURE 22B**

If only a Static Screw is desired proximally, then insert the round Static Guide Tube into the Proximal Static Screw hole of the Targeting Guide. **FIGURE 22B** Follow the technique described below, substituting the oblong Dynamic Guide Tube with the Static Tube in the Proximal Static screw hole.

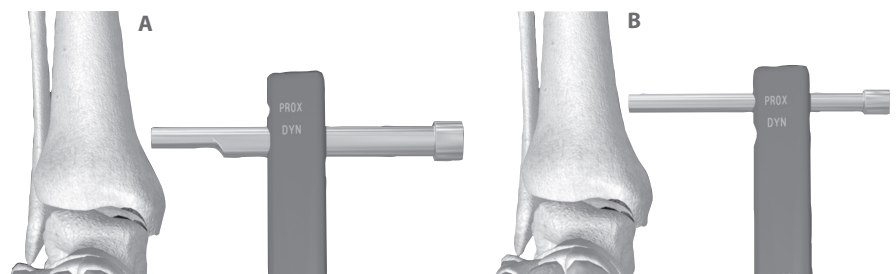

FIGURE 22
A – Orientation of the Dynamic Guide Tube for targeting of the Proximal Dynamic Screw;
B – Alignment of the Static Guide Tube for targeting of the Proximal Static Screw.

TIPS

THE IMPORTANCE OF THE TROCAR IN SCREW TARGETING

- » The Trocar should be used to create an indentation into the bone prior to drilling every screw as it ensures proper alignment of the drill.
- » Failure to indent the bone with the trocar, particularly on oblique bone surfaces such as the calcaneus, can lead to skiving of the drill and an inability to properly target the screw hole.

DETERMINING SCREW LENGTH

- » There are two methods for determining the screw length: the depth markings on the Drill and a traditional Depth Gauge.
- » To use the traditional Depth Gauge, remove the Outer Guide Tube and slide the Depth Gauge through the Targeting Guide.
- » With the Depth Gauge resting on the surface of the bone, advance the tip of the Depth Gauge until the distal cortex is hooked, and read the corresponding length on the gauge.
- » Reinsert the Outer Guide Tube.



Short 4.3mm Drill
(415S002351)



Depth Gauge
(41112016)

Slide the Drill Tube on and screw into the Outer Guide Tube. **FIGURE 23** The Entry Trocar is inserted into the Drill Tube to mark an incision point on the skin, and then retracted slightly to make the incision. After the incision is made, the Trocar is then advanced through the soft tissues to the bone's surface. The Trocar is gently impacted with a surgical mallet to make an indentation into the outer bone cortex, and the Trocar is then removed.

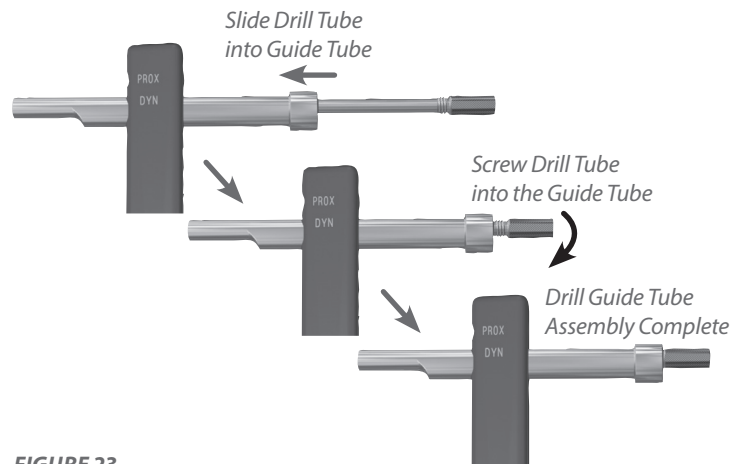

FIGURE 23
Assembly of the Drill Tube into the Outer Guide Tube.

Insert the Short Drill (415S002351) into the Drill Tube and drill bicortically through the tibial shaft.

FIGURE 24 To verify the successful targeting of the Proximal Screws, examine the Drill's final position under multiple-view fluoroscopy. Determine the screw length by reading the Depth Gauge (41112016) markings on the Drill at the end of the Drill Tube, ensuring that the Drill Guide is in full contact with the bone for accurate measurements. **FIGURE 25**

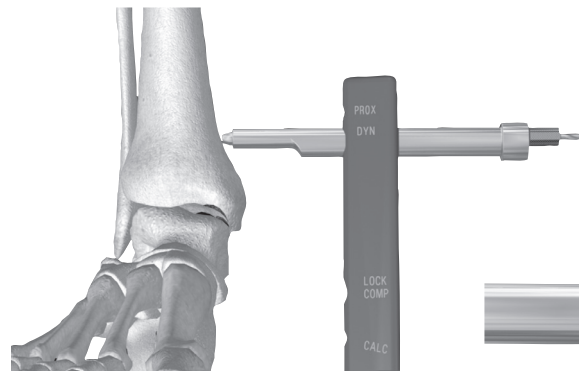

FIGURE 24
Drilling of the Proximal Dynamic Screw.

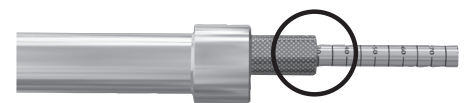

FIGURE 25
Depth markings on Drill to determine screw length.

Once the screw length is determined, remove the Short Drill and unscrew the Drill Tube from the Outer Guide Tube.

Insert the desired screw into the Outer Guide Tube. **FIGURE 26** With the STAR 25 Driver (4150003000-1) attached to the Quick Connect Handle (44180025), advance the screw through the Proximal Screw holes until fully seated. **FIGURE 27** Verify proper alignment under multiple-view fluoroscopy.

If the Proximal Dynamic Screw was inserted, repeat the above procedure with the round Static Guide Tube inserted into the Proximal Static Screw hole at the top of the Targeting Guide.



Quick Connect Handle
(44180025)



Star 25 Freehand Driver
(4150003000)



Star 25 Driver
(4150003001)

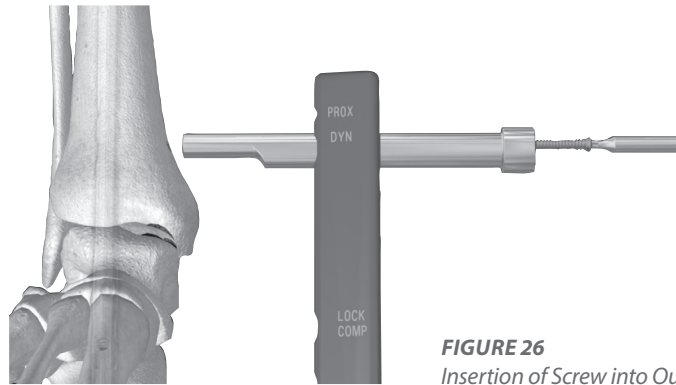

FIGURE 26
Insertion of Screw into Outer Guide Tube.

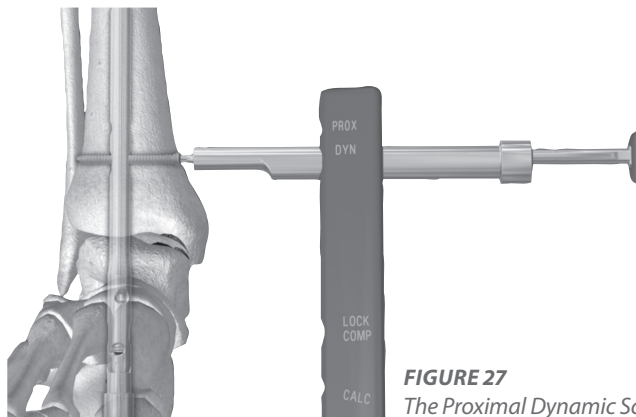

FIGURE 27
The Proximal Dynamic Screw fully seated.

COMPRESSION SCREW PLACEMENT AND INTERNAL COMPRESSION

Transverse Calcaneal Screw Placement

Activate the QwikTrigger at the base of the Targeting Guide to disengage the Connector from the Targeting Guide. **FIGURE 28** Rotate the Targeting Guide Arm to the lateral side of the foot, and lock the assembly so that it is aligned in Position 2. **FIGURE 29** Ensure that the Nail Targeting Guide connection is secure, and re-tighten with the tightening bar, as needed.

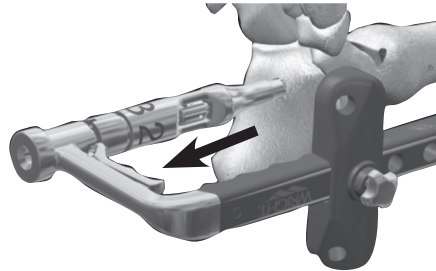

FIGURE 28
Activation of the QwikTrigger
to allow rotation of the Targeting Guide.



FIGURE 29
Alignment of Position 2.

Insert the Dynamic Guide Tube into oblong Dynamic Slot marked “Comp” (for Compression of the Calcaneal Screw) that is located near the middle of the Targeting Guide Arm. If internal compression is desired, align the length of the Dynamic Guide Tube with the “Comp” markings at the bottom of the Compression Slot. **FIGURE 30** If compression is not desired, this Calcaneal Screw will be locked by the Internal Compression Screw; orient the Dynamic Guide Tube at the top of the Compression Slot with the “Lock” markings (for Locking of the Calcaneal Screw).

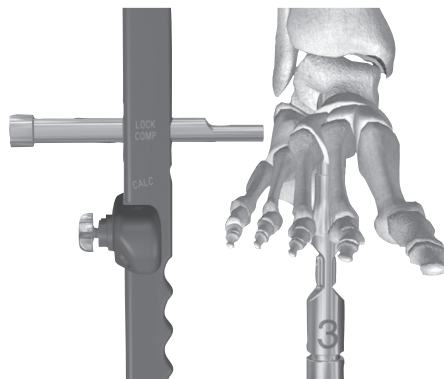

FIGURE 30
Alignment of the Dynamic Guide Tube
for Compression of the Calcaneal Screw.

TIPS

ACHIEVING A BICORTICAL BITE OF THE TRANSVERSE CALCANEAL COMPRESSION SCREW

- » The Transverse Calcaneal Screw must achieve a bicortical bite into the calcaneus, especially if internal compression will be attempted.
- » Failure to transcend the calcaneus bicortically may allow the screw to tilt as the Internal Compression Screw is advanced, causing damage to the calcaneus, ineffective compression, and malalignment of the hindfoot.
- » If drill length measures in-between available 5mm increment screw lengths, opt for the longer length to ensure a good bicortical bite.

As described previously, screw the Drill Tube into the Dynamic Guide Tube until secure. Slide the Entry Trocar into the Drill Tube to mark the skin for the incision. Make a 1cm incision and dissect the soft tissues down to the bone. Advance the Trocar, and impact gently with a surgical mallet to create an indentation onto the calcaneus to prevent skiving of the Drill.

Drill bicortically through the calcaneus with the Short Drill. **FIGURE 31** Verify under fluoroscopy that the Drill advanced through the transverse screw slot of the Nail. Once the distal cortex is broached, read the depth off the depth markings on the Drill at the end of Drill Tube, and select the corresponding screw length. Alternatively, the depth gauge may be used to determine screw length. Remove the Drill and the Drill Tube from the Dynamic Guide Tube.

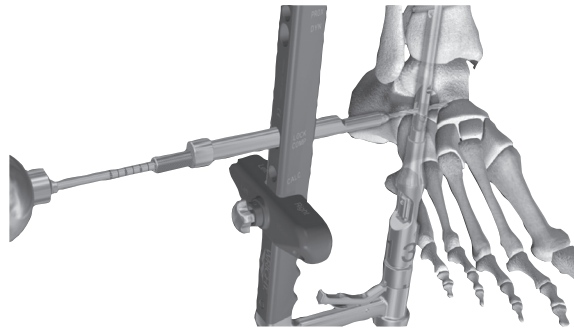

FIGURE 31
Drilling of the Transverse Calcaneal Screw.

Insert the screw into the Dynamic Guide Tube, and advance with the STAR 25 Driver connected to Quick Connect Handle. **FIGURE 32** Verify that the screw is fully seated and in proper alignment under multiple-view fluoroscopy.

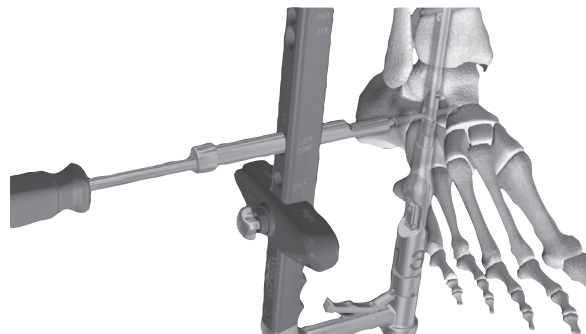

FIGURE 32
Inserting of the Transverse Calcaneal Screw.

TIPS

- » Compression will create an audible metallic interference between the screws. This noise is normal.

Internal Compression

If internal compression is desired, insert the 4.0mm Hex Driver through the base of the Targeting Guide Assembly, and advance until the Driver engages into the Internal Compression Screw. **FIGURE 33**

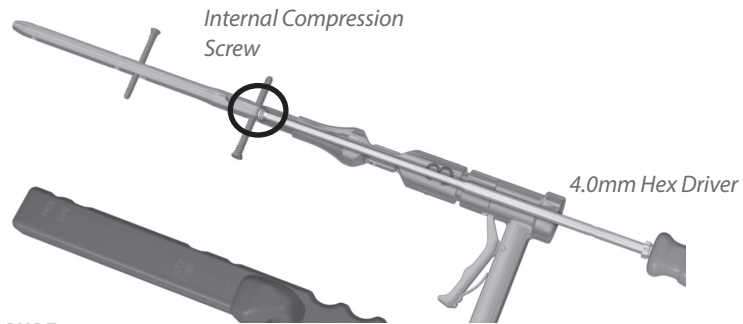

FIGURE 33
Engagement of the 4.0mm Hex Driver into the Internal Compression Screw.

The system is designed to offer up to 5mm of compression, with a minimum of 3mm needed to clear the distal Calcaneal Screw hole. Compression is achieved by advancing the Internal Compression Screw proximally into the VALOR™ Nail. **FIGURE 34** This proximal translation of the Internal Screw interferes with the Transverse Calcaneal Screw, forcing it to the top of the Calcaneal Compression slot, creating compression at the TTC joints.

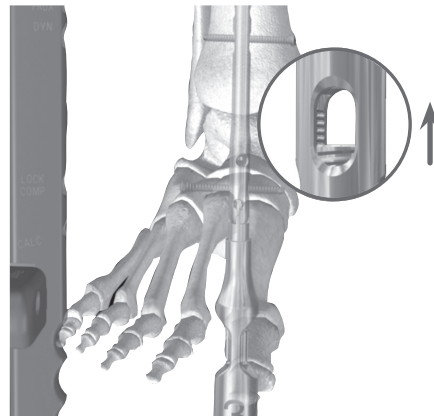

FIGURE 34
Advancement of the Internal Compression Screw, creating compression of the TTC joints.

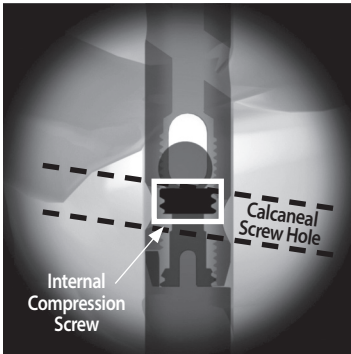

FIGURE 35
Initial fluoroscopic positioning of the Internal Compression Screw. Note the obstruction of the Calcaneal Screw hole with the Internal Compression Screw.

ENSURING CLEARANCE OF THE CALCANEAL SCREW

When initially loaded, the internal compression screw obstructs the Calcaneal Screw hole. This design affords optimal screw placement and trajectory, while still retaining the internal compression feature. A minimum compression of 3mm is required to provide sufficient clearance of the Calcaneal Screw hole. Failure to advance the Internal Compression Screw sufficiently will affect the ability to insert the distal Calcaneal Screw.

To ensure this clearance, the location of the internal compression screw should be periodically monitored during compression under fluoroscopy. The density of the internal compression screw will appear darker relative to the surrounding Nail. Prior to advancement, the compression screw will sit flush with the bottom of the Calcaneal Compression Slot. **FIGURE 35**

Advance the Internal Compression Screw with the Hex driver. A visual approximation of sufficient compression distance can be determined by the relative position of the band on the 4.0mm HEX Driver to the end of the Targeting Guide. When first engaged into the Compression Screw, the entirety of this 3.0mm long band is visible. As the Compression Screw is advanced, this band will retract into the bottom of the Targeting Guide until 3mm is achieved and the band disappears.

After the desired compression is achieved, verify the positioning of the Internal Compression Screw. The final position of the Internal Screw should provide clearance of the Calcaneal Screw hole. | **FIGURE 36** If the Compression Screw obstructs the Calcaneal Screw hole, continue compressing with the 4.0mm HEX Driver until clearance is attained.

If the Internal Compression Screw cannot be advanced the minimum of 3mm due to good apposition of the joint, two rescue options exist:

- » **Reposition Calcaneal Screw:** Retract the Internal Compression Screw and remove the Transverse Calcaneal Screw. Then, reposition the Dynamic Guide Tube in the "Locked" position. Proceed as described for no compression.
- » **Remove Internal Compression Screw:** Retract the Internal Compression Screw. Disconnect the Connector from the VALOR™ Nail, and use the 4.0mm Hex Driver to remove the Internal Compression Screw completely from the Nail. Reconnect the Connector to the Nail and continue to the Calcaneal Screw insertion.

FIGURE 36
Fluoroscopic verification of Internal Compression Screw position after compression.

- (A) A minimum compression of 3.0mm will allow clearance of the Calcaneal Screw hole (Correct).
(B) Should 3.0mm not be attained, the Internal Compression Screw will obstruct the Calcaneal Screw hole (Incorrect).

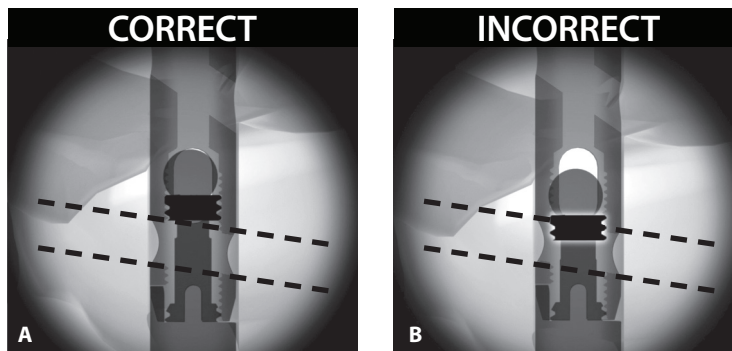

CALCANEAL SCREW PLACEMENT

Activate the QwikTrigger to disengage the Connector. Rotate and lock the Targeting Guide Arm behind the heel in Position 3 – the posterior-anterior orientation.

FIGURE 37 Verify that the Nail-Targeting Guide connection is secure, and re-tighten with the Tightening Bar, if necessary.



FIGURE 37
Alignment of Position 3.

Insert the Static Guide Tube into the “Calc” slot of the Targeting Guide, secure the Drill Tube into the Outer Guide Tube, and place the Entry Trocar into the Drill Tube to create the incision, as described previously. Gently impact the Entry Trocar to create an indentation into the calcaneus using a mallet. **FIGURE 38**

TIPS

- » Due to the oblique angles of the calcaneus, the Trocar must be used prior to insertion of the Calcaneal and Subtalar screws to prevent skiving of the Drill.
- » The oblique surface also necessitates the use of peck drilling to ensure accuracy of the Calcaneal and Subtalar Screws' trajectory.

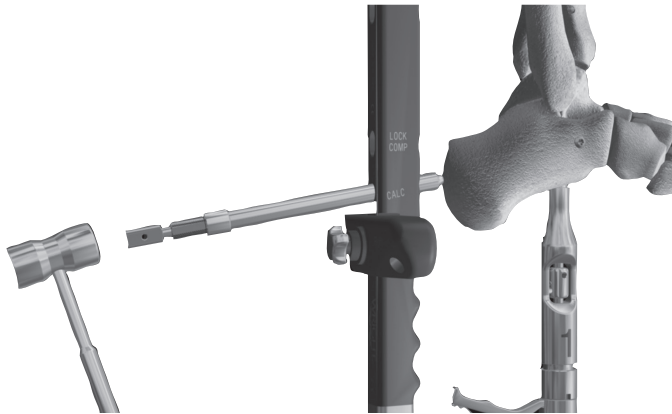

FIGURE 38
Creating indentation with Trocar using the Calcaneal Screw Assembly.

TIPS

- » As tactile feedback is poor when drilling into the calcaneus, observe the Drill's progression by constantly monitoring under a lateral fluoroscopic view.



USING POWER TO ADVANCE LONG SCREWS

- » As the length of the Calcaneal Screw makes manual screwing demanding, the Screw may be advanced initially under power.
- » Attach the STAR 25 Driver to a power unit, and advance the screw until the band on the Driver is approximately 1cm from the end of the Drill Tube.
- » This band signifies the beginning of the Proximal Screw threads biting into the cortex.
- » Replace the power unit with the Quick Connect Handle, and finish seating manually.

Peck drill through the Calcaneus with the Long Drill (415S002350 and 415S002352), stopping short of the calcaneo-cuboid joint. **FIGURE 39** Check under multiple view fluoroscopy that the Drill advanced through the Calcaneal Screw hole, axially down the body of the calcaneus. The required screw length can be determined by reading the depth off the Drill at the Drill Tube, ensuring that the Drill Tube is in full contact with the bone for accurate measurement, or with the Depth Gauge.

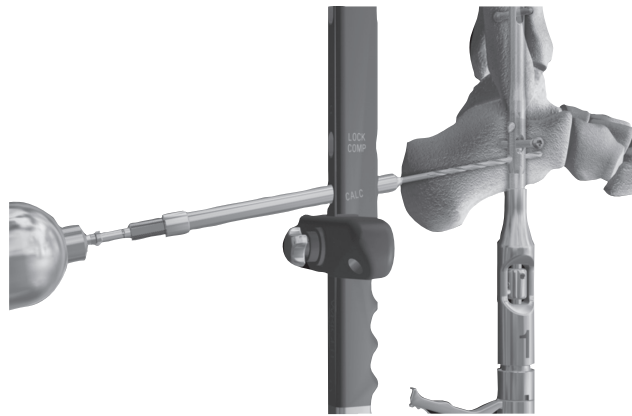

FIGURE 39
Proper alignment of Drill through the calcaneal hole.

Remove the Drill and the Drill Tube.

Insert the Calcaneal Screw with the STAR 25 Driver. **FIGURE 40** Verify that the screw is fully seated and in proper alignment under multiple-view fluoroscopy.

Remove the Driver and Static Guide Tube.



FIGURE 40
Inserting the Calcaneal Screw.

TIPS

- » If the Calcaneal Screw is not properly positioned in the calcaneus, the rotational alignment of the Targeting Guide may cause poor positioning of the Subtalar Screw.
- » In the supine position, careful consideration must be paid to the Guide Tube and its instrumentation, as instruments have a tendency to slide out of the Outrigger Guide.

SUBTALAR SCREW PLACEMENT

Insert the Static Guide Tube into either the “Left” or “Right” hole on the Targeting Guide Outrigger, depending on the orientation of the VALOR™ Nail. **FIGURE 41** Slide the Drill Tube into the Guide Tube and screw to secure.



FIGURE 41
Plantar view of the Subtalar Guide orientation for a Right VALOR™ Nail.

Insert the Entry Trocar into the Drill Tube to mark incision point on the skin. Retract Trocar slightly, and make incision. After the incision is complete, advance Trocar to bone, and make an indentation into the calcaneal cortex. **FIGURE 42** Ensuring a good Trocar indentation into the cortex of the calcaneus is especially important for the Subtalar screw due to the angled surface of the calcaneus.



FIGURE 42
Creating an indentation into the calcaneus with the Entry Trocar.

Drill through the calcaneus and into the talus with the Long Drill, ensuring that the Drill penetrates the distal cortex of the talus. Peck drilling is often necessary to ensure that the drill does not walk or skive. Verify positioning of the Drill under continuous fluoroscopy in both AP and ML views. Determine the screw length from the depth markings on the Drill or using the Depth Gauge.

Remove the Drill and the Drill Tube.

Insert the Subtalar Screw with the STAR 25 Driver.

TIPS

- » The Proximal Freehand Screw can provide additional translational and rotational stability to the proximal tip of the VALOR™ Nail.
- » Usage of the Proximal Freehand Screw is especially beneficial if a longer Nail was used, when the bone quality is poor, or if the tibia's diaphyseal canal was reamed 1.0mm or more.

Proximal Freehand Screw (Optional)

Align a lateral fluoroscopic view so that the Proximal Freehand hole is a perfect circle. Place the tip of the Freehand Drill against the skin and reposition under fluoroscopy until the tip aligns with the center of the hole. **FIGURE 43** Mark the skin at the tip of the Drill.

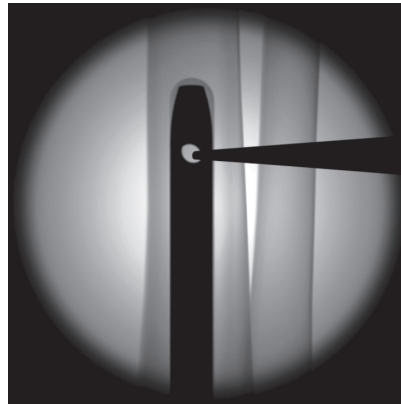

FIGURE 43
Fluoroscopic assessment of Proximal Freehand Screw hole location.

Make a 1cm incision at the mark, and dissect down to bone. Repeat the fluoroscopic alignment procedure with the Drill in the incision, and set the Drill tip onto bone once satisfied. Begin drilling, proceeding until the Drill has broken through the distal cortex. Use the Depth Gauge to determine screw length. **FIGURE 44** Insert the Proximal Freehand Screw using the Proximal Freehand Driver. **FIGURE 45**

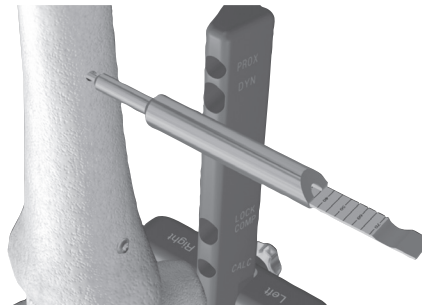

FIGURE 44
Determining Proximal Freehand Screw length with Depth Gauge.

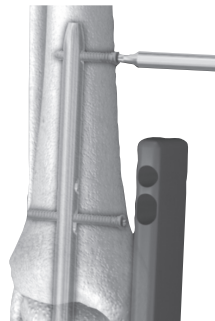

FIGURE 45
Seating of the Proximal Freehand Screw.

Verifying Final Positioning of the Screws

A final verification of screw positions is performed under multiple view fluoroscopy, checking to ensure that the screws were successfully placed through the VALOR™ Nail and have achieved adequate bone purchase. **FIGURE 46**

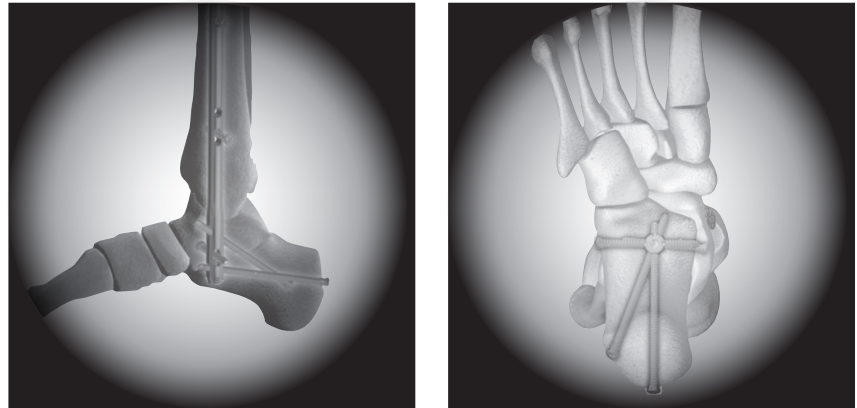

FIGURE 46
Fluoroscopic verification of final Screw positions.

TIPS

- » It is often helpful to provide upward pressure at the base of the Targeting Guide to allow for axial alignment of the Connector with the Nail, which assists in the movement of the Connection Screw.

Disassembling the Targeting Guide

Disconnect the Connector from the VALOR™ Nail by unscrewing the Thumb Wheel on the Connector. To initiate movement of the Thumb Wheel, it is often necessary to use the Tightening Bar. **FIGURE 47**

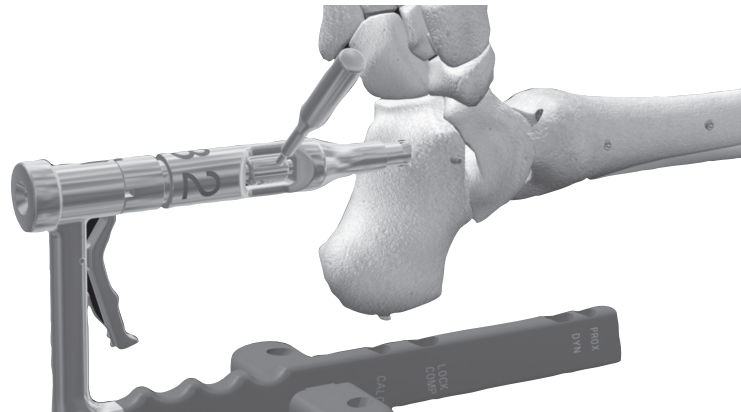

FIGURE 47
Unscrewing the Thumb Wheel with the Tightening Bar.

Remove the Connector from the main Targeting Guide by activating the QwikTrigger and sliding the Connector up. Detach the Outrigger by loosening the Thumb Screw and sliding up and out.

TIPS

- » While optional, the End Cap provides several important features:
 - » Locks the Calcaneal Screw into the distal Calcaneal Screw hole, preventing back-out.
 - » Protects the distal end of the VALOR™ Nail.
 - » Prevents the intrusion of bone and soft-tissues into the Nail, thereby making removal easier.



End Cap Insertion (Optional)

The End Cap can be inserted into the VALOR™ Nail by using the 4.0mm Hex Driver, and screwing into the internal distal threads of the Nail. **FIGURE 48**

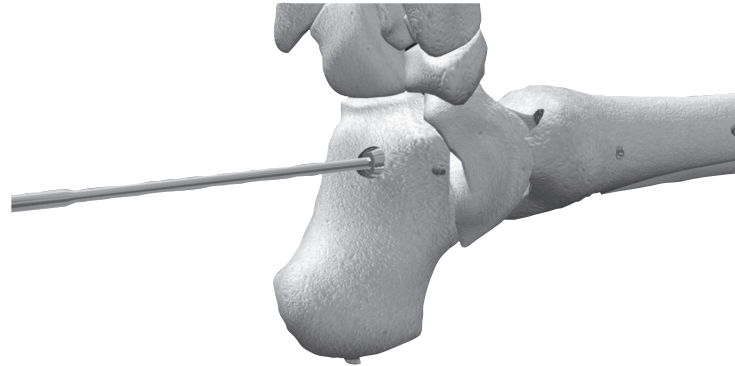

FIGURE 48
Insertion of the End Cap using the Hex Driver.

Explant Information

The Star 25 Driver will be used to remove all Locking Screws.

Use the 4.0mm Hex driver to remove the End Cap. Remove the most inferior calcaneal screw. Back off the internal compression screw using the 4.0mm Hex Driver, and remove the transverse calcaneal screw. Next, remove the subtalar screw. At this point attach the VALOR™ Nail Extractor (4150005002) to the nail. Ensure that the extractor is firmly attached to the end of the nail. Remove all proximal locking screws, and remove the nail by lightly back slapping the extractor with the VALOR™ Nail Slap Hammer.

If the removal of the implant is required due to revision or failure of the device, the surgeon should contact the manufacturer using the contact information located on the back cover of this surgical technique to receive instructions for returning the explanted device to the manufacturer for investigation.

Postoperative Care

Postoperative care is left to the discretion of the surgeon.

Ordering Information

IMPLANTS

Right VALOR™ Nail Implant Kit – 4150KITR

PART NUMBER	DESCRIPTION	DIAMETER	LENGTH	QUANTITY
415101015R	10.0MM VALOR™ NAIL – RIGHT SMALL	10.0MM	150MM	1
415101020R	10.0MM VALOR™ NAIL – RIGHT MEDIUM	10.0MM	200MM	1
415101025R	10.0MM VALOR™ NAIL – RIGHT LARGE	10.0MM	250MM	1
415101030R	10.0MM VALOR™ NAIL – RIGHT X-LARGE	10.0MM	300MM	1
415101115R	11.5MM VALOR™ NAIL – RIGHT SMALL	11.5MM	150MM	1
415101120R	11.5MM VALOR™ NAIL – RIGHT MEDIUM	11.5MM	200MM	1
415101125R	11.5MM VALOR™ NAIL – RIGHT LARGE	11.5MM	250MM	1
415101130R	11.5MM VALOR™ NAIL – RIGHT X-LARGE	11.5MM	300MM	1

Left VALOR™ Nail Implant Kit – 4150KITL

PART NUMBER	DESCRIPTION	DIAMETER	LENGTH	QUANTITY
415101015L	10.0MM VALOR™ NAIL – LEFT SMALL	10.0MM	150MM	1
415101020L	10.0MM VALOR™ NAIL – LEFT MEDIUM	10.0MM	200MM	1
415101025L	10.0MM VALOR™ NAIL – LEFT LARGE	10.0MM	250MM	1
415101030L	10.0MM VALOR™ NAIL – LEFT X-LARGE	10.0MM	300MM	1
415101115L	11.5MM VALOR™ NAIL – LEFT SMALL	11.5MM	150MM	1
415101120L	11.5MM VALOR™ NAIL – LEFT MEDIUM	11.5MM	200MM	1
415101125L	11.5MM VALOR™ NAIL – LEFT LARGE	11.5MM	250MM	1
415101130L	11.5MM VALOR™ NAIL – LEFT X-LARGE	11.5MM	300MM	1

VALOR™ Screw Implant Kit – 4150KITA

PART NUMBER	DESCRIPTION	DIAMETER	LENGTH	QUANTITY
4151150020	VALOR™ SCREW 5.0MM X 20MM	5.0MM	20MM	1
4151150025	VALOR™ SCREW 5.0MM X 25MM	5.0MM	25MM	2
4151150030	VALOR™ SCREW 5.0MM X 30MM	5.0MM	30MM	3
4151150035	VALOR™ SCREW 5.0MM X 35MM	5.0MM	35MM	3
4151150040	VALOR™ SCREW 5.0MM X 40MM	5.0MM	40MM	3
4151150045	VALOR™ SCREW 5.0MM X 45MM	5.0MM	45MM	3
4151150050	VALOR™ SCREW 5.0MM X 50MM	5.0MM	50MM	2
4151150055	VALOR™ SCREW 5.0MM X 55MM	5.0MM	55MM	2
4151150060	VALOR™ SCREW 5.0MM X 60MM	5.0MM	60MM	2
4151150065	VALOR™ SCREW 5.0MM X 65MM	5.0MM	65MM	2
4151150070	VALOR™ SCREW 5.0MM X 70MM	5.0MM	70MM	3
4151150075	VALOR™ SCREW 5.0MM X 75MM	5.0MM	75MM	3
4151150080	VALOR™ SCREW 5.0MM X 80MM	5.0MM	80MM	2
4151150085	VALOR™ SCREW 5.0MM X 85MM	5.0MM	85MM	2
4151150090	VALOR™ SCREW 5.0MM X 90MM	5.0MM	90MM	2
4151150095	VALOR™ SCREW 5.0MM X 95MM	5.0MM	95MM	2
4151150100	VALOR™ SCREW 5.0MM X 100MM	5.0MM	100MM	1
4151150105	VALOR™ SCREW 5.0MM X 105MM	5.0MM	105MM	1
4151150110	VALOR™ SCREW 5.0MM X 110MM	5.0MM	110MM	1
4151150115	VALOR™ SCREW 5.0MM X 115MM	5.0MM	115MM	1
4151150120	VALOR™ SCREW 5.0MM X 120MM	5.0MM	120MM	1
4151200003	VALOR™ NAIL END CAP			2
4150004025	VALOR™ NAIL 3.0MM ENTRY GUIDEWIRE			2
4150004030	VALOR™ NAIL 3.0MM BEADED-TIP GUIDEWIRE			2
415S002350	VALOR™ 4.3MM FREEHAND DRILL			1
415S002351	VALOR™ 4.3MM SHORT DRILL			2
415S002352	VALOR™ 4.3MM LONG DRILL			2

INSTRUMENTS

VALOR™ Nail Instrument Kit – 4150KIT1

PART NUMBER	DESCRIPTION	DIAMETER
4150011000	VALOR™ TARGETING GUIDE	1
4150011002	VALOR™ SUBTALAR OUTRIGGER GUIDE	1
4150011003	VALOR™ GUIDE CONNECTOR – LEFT	1
4150011004	VALOR™ GUIDE CONNECTOR – RIGHT	1
4150001010	VALOR™ DYNAMIC GUIDE TUBE	1
4150011011	VALOR™ STATIC GUIDE TUBE	2
4150011012	VALOR™ DRILL TUBE	2
4150011013	VALOR™ TISSUE PROTECTOR	1
4150001014	VALOR™ TIGHTENING BAR	1
4150012000	VALOR™ ENTRY TROCER	1
4150002090	VALOR™ 9.0MM X 250MM STEPPED REAMER	1
4150003000	VALOR™ NAIL STAR 25 FREEHAND DRIVER	1
4150003001	VALOR™ NAIL STAR 25 DRIVER	1
4150003040	VALOR™ NAIL 4.0MM HEX DRIVER	1
4150005000	VALOR™ BACK-OUT PLATE	1
4150005001	VALOR™ NAIL SLAP HAMMER	1
4150005002	VALOR™ NAIL EXTRACTOR	1
4150016000	VALOR™ FLEXIBLE REAMER SHAFT	1
4150006090	VALOR™ FLEXIBLE REAMER HEAD – 9.0MM	1
4150006095	VALOR™ FLEXIBLE REAMER HEAD – 9.5MM	1
4150006100	VALOR™ FLEXIBLE REAMER HEAD – 10.0MM	1
4150006105	VALOR™ FLEXIBLE REAMER HEAD – 10.5MM	1
4150006110	VALOR™ FLEXIBLE REAMER HEAD – 11.0MM	1
4150006115	VALOR™ FLEXIBLE REAMER HEAD – 11.5MM	1
4150006120	VALOR™ FLEXIBLE REAMER HEAD – 12.0MM	1
4150006125	VALOR™ FLEXIBLE REAMER HEAD – 12.5MM	1
44180025	7.0 MUC HANDLE QUICK CONNECT	1
41112016	DEPTH GAUGE	1
4150010100	VALOR™ NAIL TRAY	1

TEMPLATES

PART NUMBER	DESCRIPTION
415000XR00	VALOR™ NAIL TEMPLATE - 100%
415000XR10	VALOR™ NAIL TEMPLATE - 110%
415000XR15	VALOR™ NAIL TEMPLATE - 115%

Instrumentation and Consumables



Stepped Reamer
(Part No. 4150002090)



Tissue Protector
(Part No. 4150011013)



Flexible Reamer Shaft
(Part No. 4150016000)



Flexible Reamer Head
(Part No. 4150006090-6125)



Targeting Guide
(Part No. 4150011000)



Subtalar Outrigger Guide
(Part No. 4150011002)



Guide Connector - Left
(Part No. 4150011003)



Guide Connector - Right
(Part No. 4150011004)



Tightening Bar
(Part No. 4150001014)



Slap Hammer
(Part No. 4150005001)



Extractor
(Part No. 4150005002)



Back-Out Plate
(Part No. 4150005000)



4.0mm Hex Driver
(Part No. 4150003040)



Dynamic Guide Tube
(Part No. 4150001010)



Static Guide Tube
(Part No. 4150011011)



Drill Tube
(Part No. 4150011012)



Entry Trocar
(Part No. 4150012000)



Star 25 Driver
(Part No. 4150003001)



Star 25 Freehand Driver
(Part No. 4150003000)

CONSUMABLES



3.0mm Entry Guidewire
(Part No. 4150004025)

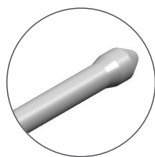

3.0mm Beaded-Tip Guidewire
(Part No. 4150004030)



Freehand 4.3mm Drill
(Part No. 415S002350)



Short 4.3mm Drill
(Part No. 415S002351)



Long 4.3mm Drill
(Part No. 415S002352)



Stryker South Pacific
8 Herbert Street
St. Leonards, NSW
Australia
Ph. 02 9467 1000

™ and ® denote Trademarks and Registered Trademarks of Wright Medical Group N.V. or its affiliates.
©2019 Wright Medical Group N.V. or its affiliates. All Rights Reserved.