

# SALVATION™ 2

Limb Salvage System



MORE SIMPLE  
MORE STABLE  
MORE COMPREHENSIVE

 **WRIGHT™**  
FOCUSED EXCELLENCE

# SALVATION™ 2

## Limb Salvage System

### System Features

The SALVATION 2 External Fixation System is designed to address fractures, nonunions, and complex foot and ankle deformities including Charcot neuroarthropathy. The SALVATION 2 External Fixation System incorporates many new features to make limb salvage more simple, more stable, and more comprehensive. The preassembled slotted ring design allows for frame components to be attached quickly and easily, while minimizing the need to assemble small, threaded components together.

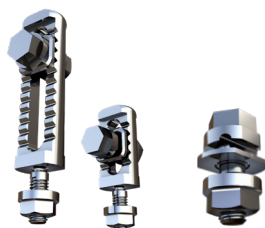
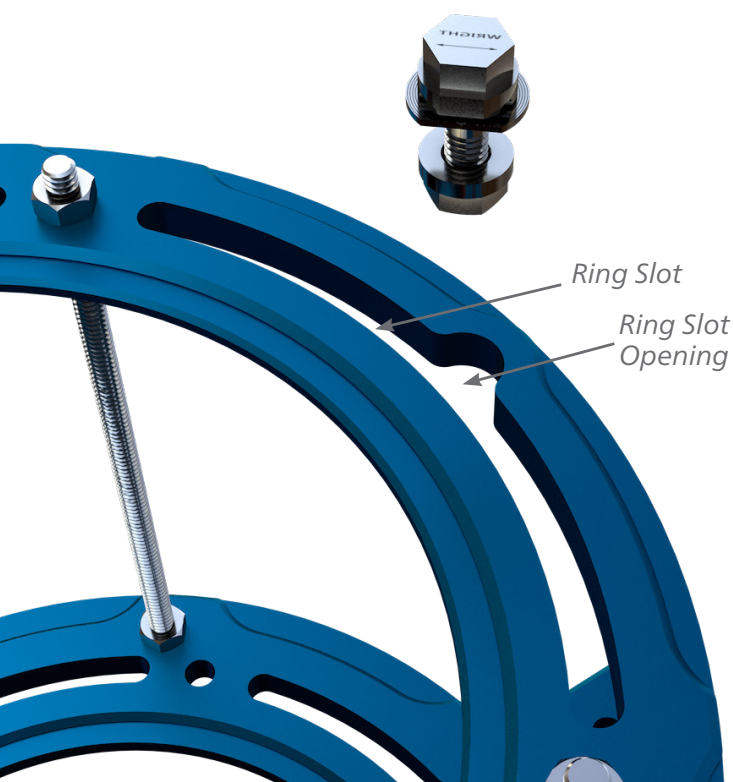

Wire Post

Wire Bolt

### Preassembled Components

Preassembled wire bolts and wire posts are mounted using the system's new slotted ring design, saving time and streamlining frame application.

### Patient Positioning Tools

These components assist in positioning the foot and lower leg within the frame to maintain appropriate position throughout the surgery.

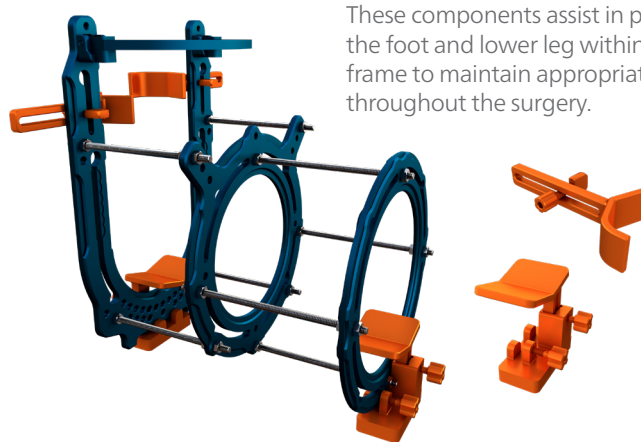

### Reproducible Wire Replacement

The wire guide allows for precise placement of the wire on the ring to minimize the need for additional connection components and decrease additional surgical steps.



1023 Cherry Road  
Memphis, TN 38117  
800 238 7117  
901 867 9971  
www.wright.com

56 Kingston Road  
Staines-upon-Thames  
Surrey TW18 4NL  
United Kingdom  
+44 (0)845 833 4435

161 Rue Lavoisier  
38330 Montbonnot Saint Martin  
France  
+33 (0)4 76 61 35 00

™ and ® denote Trademarks and Registered Trademarks of Wright Medical Group N.V. or its affiliates.  
©2018 Wright Medical Group N.V. or its affiliates. All Rights Reserved.

013468B\_17-May-2018